

| SILENT FLOOR PUR

TECHNICAL MANUAL

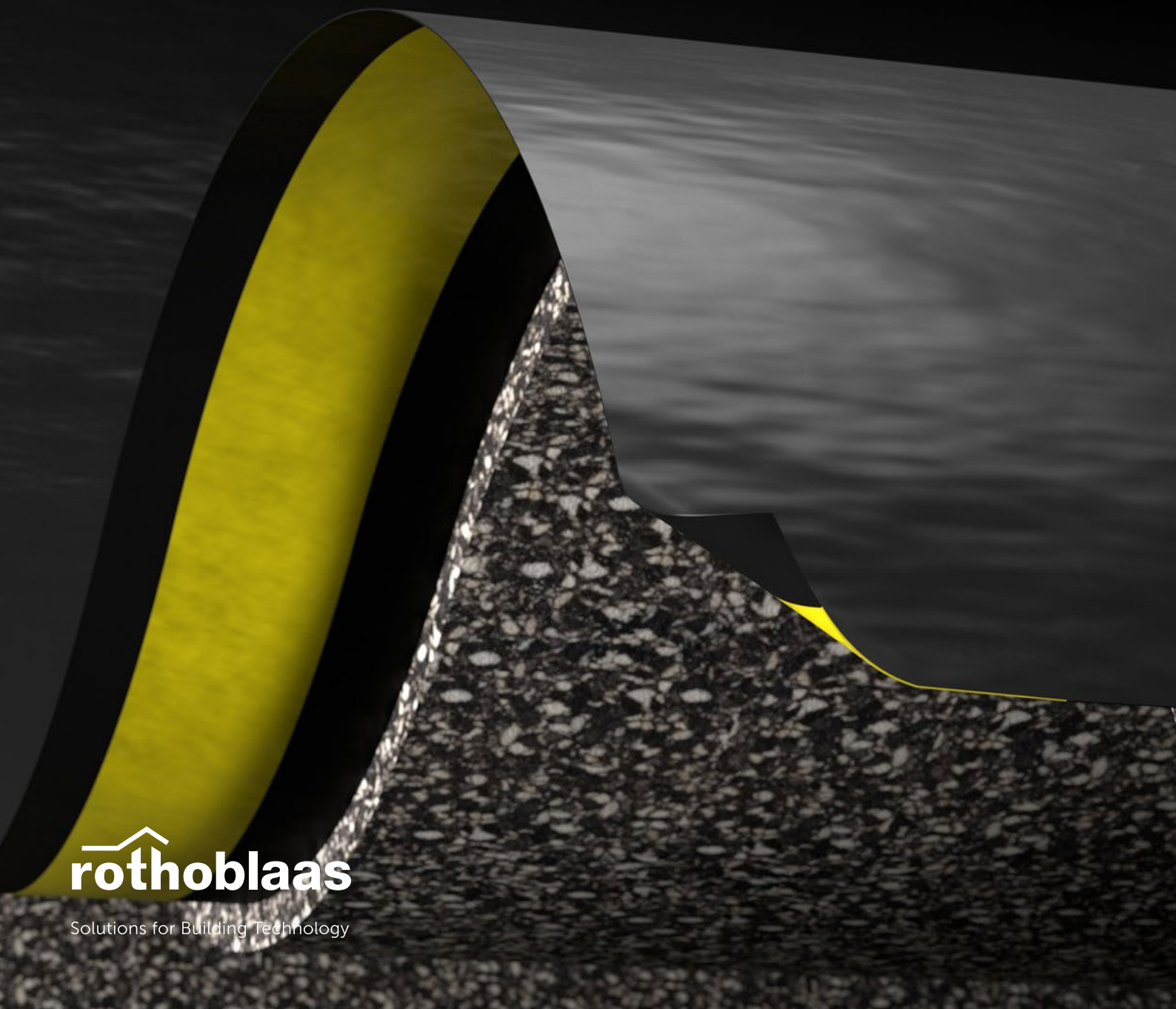

**rothoblaas**

Solutions for Building Technology

CONTENTS

PROBLEMI ACUSTICI DEI SOLAI	4
SILENT FLOOR PUR	6
SILFLOORPUR10	8
<i>IMPACT NOISE INSULATION ACCORDING TO</i>	
<i>SCREED THICKNESS</i>	9
<i>ON-SITE MEASUREMENT CLT FLOOR 1</i>	10
<i>LABORATORY MEASUREMENT CLT FLOOR 2</i>	12
<i>LABORATORY MEASUREMENT CLT FLOOR 3</i>	14
<i>LABORATORY MEASUREMENT FRAME WALL 4A</i>	16
<i>LABORATORY MEASUREMENT CLT FLOOR 4B</i>	17
<i>LABORATORY MEASUREMENT FRAME WALL 5A</i>	18
<i>LABORATORY MEASUREMENT FRAME WALL 5B</i>	19
<i>LABORATORY MEASUREMENT FRAME WALL 6A</i>	20
<i>LABORATORY MEASUREMENT FRAME WALL 6B</i>	21
<i>LABORATORY MEASUREMENT FRAME WALL 7A</i>	22
<i>LABORATORY MEASUREMENT FRAME WALL 7B</i>	23
ON SITE MEASUREMENTS	24
SILFLOORPUR15	25
<i>LABORATORY MEASUREMENT CLT FLOOR 1</i>	26
<i>LABORATORY MEASUREMENT CLT FLOOR 2</i>	28
SILFLOORPUR20	31
<i>LABORATORY MEASUREMENT CLT FLOOR 1</i>	32

ACOUSTIC PROBLEMS OF FLOORS



WHAT IS IMPACT NOISE?

When it comes to floors, impact noise is the main acoustic problem because it constantly affects them. When a body impacts on the floor structure, the noise quickly spreads throughout the building either by air, affecting the nearest rooms, or by structure, propagating into the most distant rooms.

WHAT IS AIRBORNE NOISE?

Airborne noise is generated in the air and, after an initial airborne phase, is transported both by air and by structure. This is a problem that affects both walls and floors, but if we are talking about floors, the most important problem is certainly impact noise.

HERE IS THE SOLUTION

In order to be able to minimise the discomfort caused by impact noise, a stratigraphic package should be designed consisting of layers of different materials that are disconnected from each other and are able to dissipate the energy transmitted by the impact.



MASS-SPRING-MASS SYSTEM

A floating screed system such as the one shown in the images below can be schematised with a mass-spring-mass system, in which the structural floor represents the mass, the impact-absorbing product is equivalent to the spring, and the upper screed with the floor constitutes the second mass of the system. In this context, "resilient layer" is defined as the element with the spring function characterised by its own *dynamic stiffness s'*.

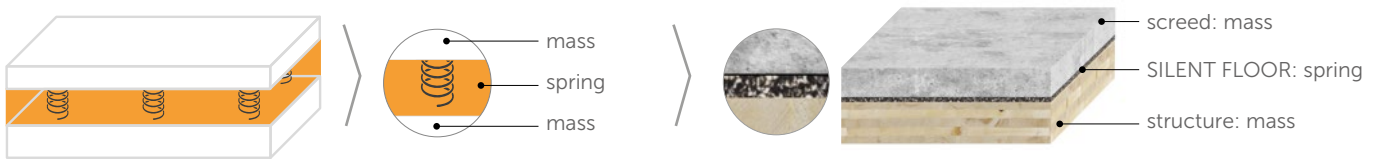

HOW IS THE IMPACT NOISE LEVEL MEASURED?

The impact noise level is a measure of the disturbance perceived in a room when an impact noise source is activated in the upper room. It can be measured both on site and in the laboratory. Clearly, ideal conditions exist in the laboratory for the effects of lateral transmission to be neglected, as the laboratory itself is constructed so that the walls are decoupled from the ceiling.

TAPPING MACHINE method

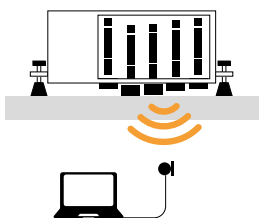

The TAPPING MACHINE is used to simulate "light" and "hard" impacts, such as walking with heeled shoes or the impact caused by falling objects.

RUBBER BALL method

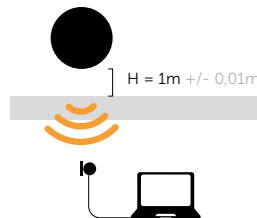

The RUBBER BALL is used to simulate "soft" and "heavy" impacts, such as a barefoot walk or a child jumping.

HOW TO CHOOSE THE BEST PRODUCT

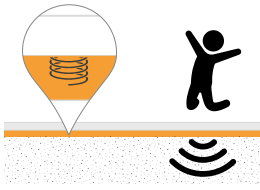

DYNAMIC STIFFNESS – s'

Expressed in MN/m^3 , it is measured according to EN 29052-1 and expresses the deformation capacity of a material that is subjected to a dynamic stress. Consequently, it indicates the ability to dampen the vibrations generated by an impact noise.

The measurement method involves, first, measuring the *apparent dynamic stiffness* s'_t of the material and then correcting it, if necessary, to obtain the *real dynamic stiffness* s' . Dynamic stiffness depends in fact on the *flow resistivity* r , which is measured in the lateral direction of the sample. If the material has specific flow resistivity values, the apparent dynamic stiffness must be corrected by adding the contribution of the gas contained within the material: air.

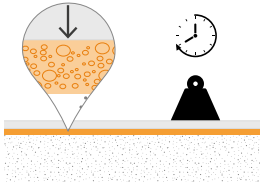

VISCOUS SLIDING UNDER COMPRESSION – CREEP

Expressed as a percentage, it is measured according to EN 1606 and represents the long-term deformation of a material under constant load to be simulated. The measurement in the laboratory must be carried out over a period of at least 90 days.

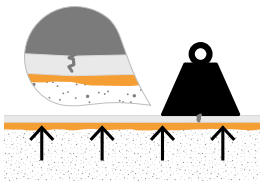

COMPRESSIBILITY - c

The compressibility class expresses the behaviour of a material while subjected to screed loading. During measurement, the product is subjected to different loads and its thickness is measured. The compressibility measurement is carried out to understand what loads the underscreed product can withstand, in order to avoid cracking and splitting of screeds.

CORRECT INSTALLATION

The technological solution of the floating screed is one of the most widely used and one of the most effective, but in order to achieve satisfactory results it is important that the system is designed and implemented correctly.

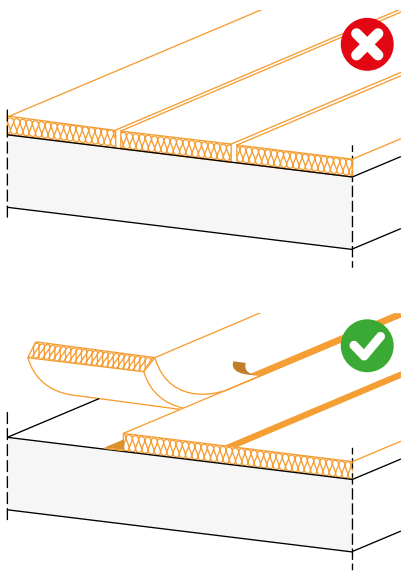

The resilient layer must be continuous because any gap would represent an acoustic bridge. When installing underscreed mats, care must be taken not to create discontinuities.

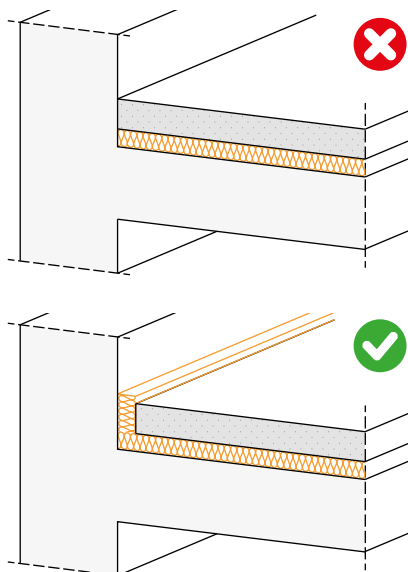

It is important to use the SILENT EDGE perimeter strip to ensure that the resilient layer is continuous around the entire perimeter of the room. The SILENT EDGE should only be trimmed after the floor has been installed and grouted.

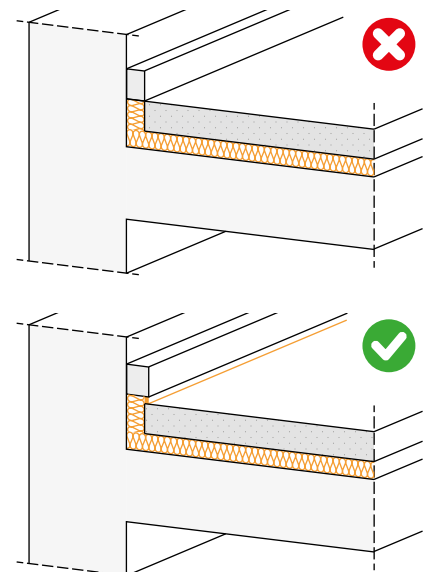

The skirting board must be installed after the SILENT EDGE has been cut, ensuring that it is always suitably raised from the floor.

IIC vs L_w

IIC stands for **Impact Insulation Class** and is the value obtained by subtracting the noise level measured in the receiving room from the noise level measured in the source room. Impact Insulation Class, sometimes referred to as Impact Isolation Class, measures the resistance of the floor construction assembly against the propagation of impact-generated noise.

SILENT FLOOR PUR

RESILIENT HIGH PERFORMANCE UNDERSCREED MEMBRANE
MADE OF RECYCLED POLYMERS

CERTIFIED

The effectiveness of the underscreed membrane has been certified in the labs of the Centre for Industrial Research of the University of Bologna.

SUSTAINABILITY

Recycled and recyclable. The product intelligently reuses polyurethane from production waste that would otherwise have to be disposed of.

HIGH PERFORMANCE

The special composition offers excellent elasticity, reaching attenuation values over 30 dB.



COMPOSITION

polyethylene vapour barrier

polyurethane agglomerate made from pre-consumer industrial waste

CODES AND DIMENSIONS

CODE	H ⁽¹⁾ [m]	L [m]	thickness [mm]	A _f ⁽²⁾ [m ²]	
SILFLOORPUR10	1,6	10	10	15	6
SILFLOORPUR15	1,6	8	15	12	6
SILFLOORPUR20	1,6	6	20	9	6

⁽¹⁾1.5 m of polyurethane agglomerate and vapour barrier + 0.1 m of vapour barrier for overlap with integrated adhesive strip.

⁽²⁾Without considering the overlap area.



SAFE

Polyurethane is a noble polymer that maintains elasticity over time, without subsidence or changes in performance.

VOC REQUIREMENTS

The membrane composition safeguards health and meets the recommended VOC limits.

PRODUCT STRATIGRAPHY COMPARISON

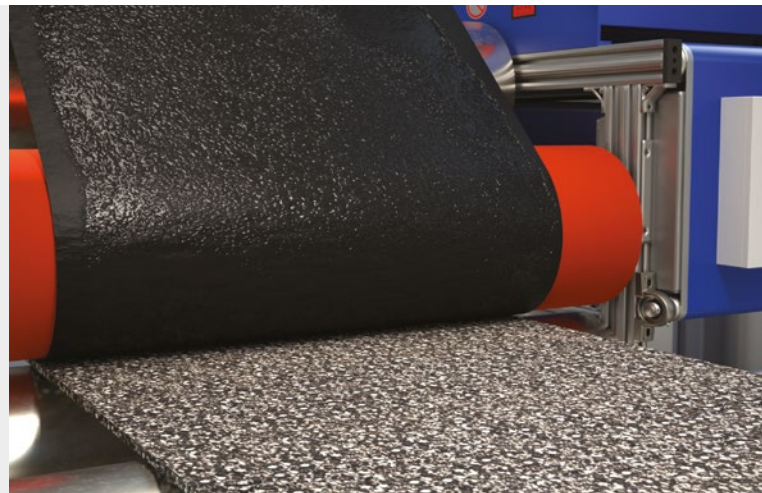
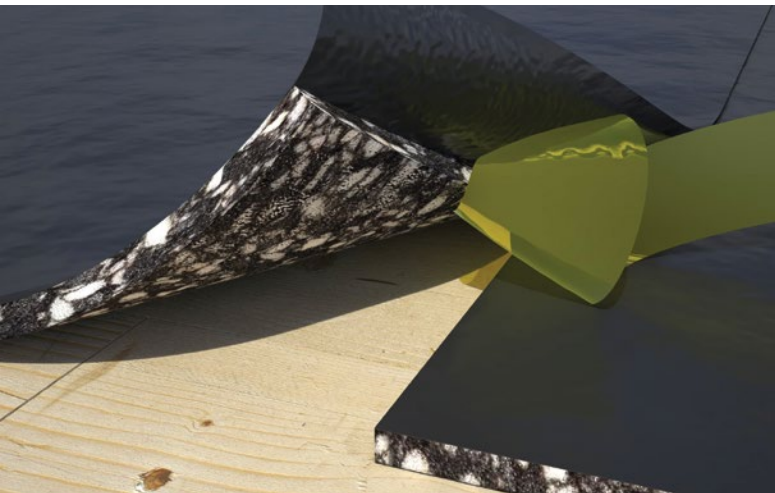
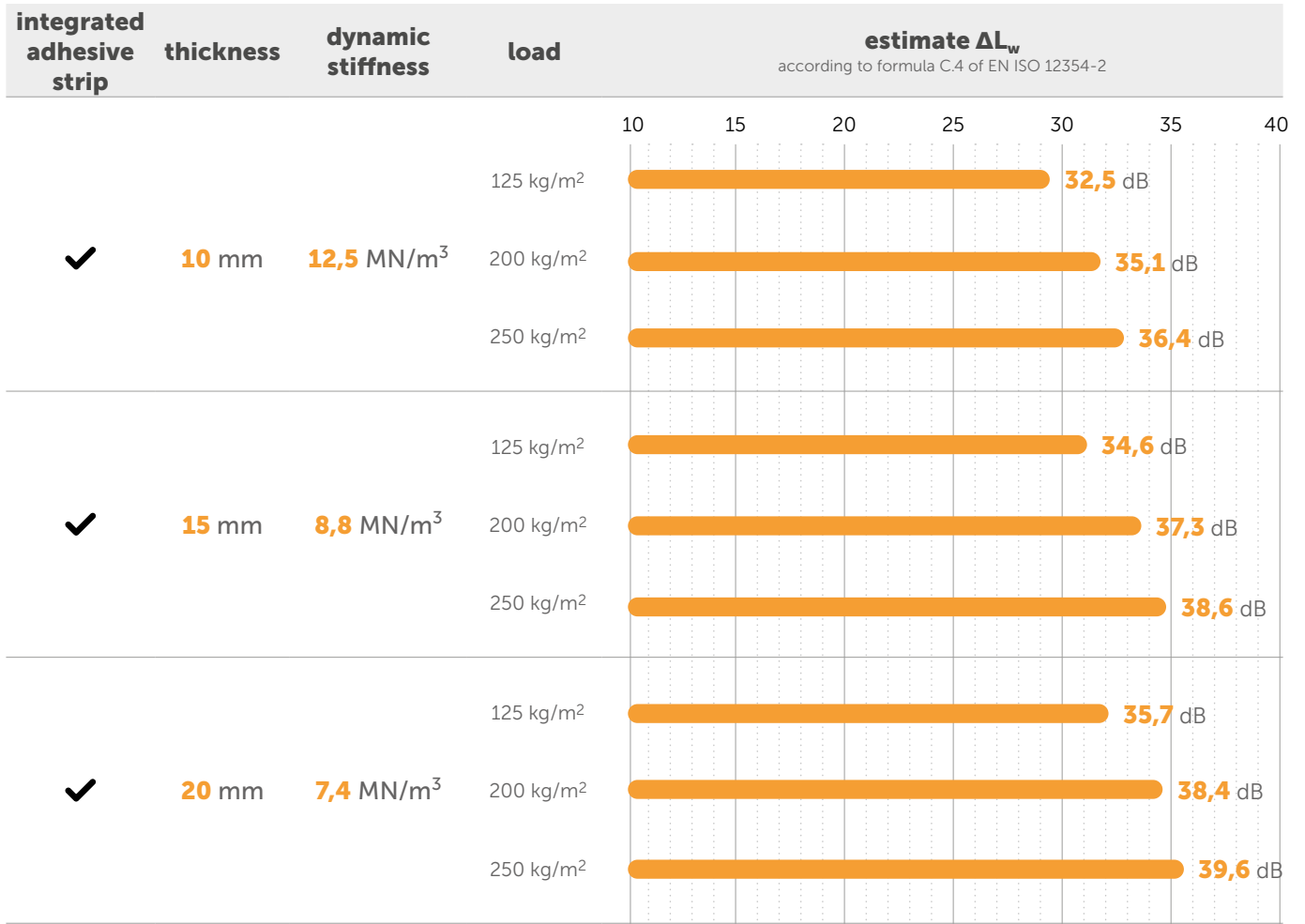

SILFLOORPUR10

TECHNICAL DATA

Properties	standard	value
Surface mass m	-	0,9 kg/m ²
Density ρ	-	80 kg/m ³
Apparent dynamic stiffness s' _t	EN 29052-1	12,5 MN/m ³
Dynamic stiffness s'	EN 29052-1	12,5 MN/m ³
Theoretical estimate of impact sound pressure level attenuation ΔL _w ⁽¹⁾	ISO 12354-2	32,5 dB
System resonance frequency f ₀ ⁽²⁾	ISO 12354-2	50,6 Hz
Impact sound pressure level attenuation ΔL _w ⁽³⁾	ISO 10140-3	21 dB
Thermal resistance R _t	-	0,46 m ² K/W
Resistance to airflow r	ISO 9053	< 10,0 kPa·s·m ⁻²
Compressibility class	EN 12431	CP2
CREEP Viscous sliding under compression X _{ct} (1,5 kPa)	EN 1606	7,50 %
Compression deformation stress	ISO 3386-1	17 kPa
Thermal conductivity λ	-	0,035 W/m·K
Specific heat c	-	1800 J/kg·K
Water vapour transmission Sd	-	> 100 m
Reaction to fire	EN 13501-1	class F
VOC emission classification	French decree no. 2011-321	A+

⁽¹⁾ΔL_w= (13 lg(m'))-(14,2 lg(s'))+20,8 [dB] con m'= 125 kg/m².

⁽²⁾f₀= 160 √(s'/m') con m'= 125 kg/m².

⁽³⁾Measured in the laboratory on 200 mm CLT floor. See the manual for more information on configuration.

EN ISO 12354-2 ANNEX C | ESTIMATE ΔL_w (FORMULA C.4) E ΔL (FORMULA C.1)

The following tables show how the attenuation in dB (ΔL_w e ΔL) of SILFLOORPUR10 varies as the load m' (i.e., the surface mass of the layers with which SILFLOORPUR10 is loaded) changes.

SILFLOORPUR10

s't or s'	12,5	12,5	12,5	12,5	12,5	12,5	12,5	12,5	12,5	12,5	12,5	12,5	[MN/m ³]
load m'	50	75	100	125	150	175	200	225	250	275	300		[kg/m ²]
ΔL _w	27,3	29,6	31,2	32,5	33,5	34,4	35,1	35,8	36,4	36,9	37,4		[dB]
f ₀	80,0	65,3	56,6	50,6	46,2	42,8	40,0	37,7	35,8	34,1	32,7		[Hz]

ΔL in frequency

[Hz]	100	2,9	5,5	7,4	8,9	10,1	11,1	11,9	12,7	13,4	14,0	14,6	[dB]
[Hz]	125	5,8	8,5	10,3	11,8	13,0	14,0	14,8	15,6	16,3	16,9	17,5	[dB]
[Hz]	160	9,0	11,7	13,5	15,0	16,2	17,2	18,1	18,8	19,5	20,1	20,7	[dB]
[Hz]	200	11,9	14,6	16,5	17,9	19,1	20,1	21,0	21,7	22,4	23,0	23,6	[dB]
[Hz]	250	14,8	17,5	19,4	20,8	22,0	23,0	23,9	24,6	25,3	26,0	26,5	[dB]
[Hz]	315	17,9	20,5	22,4	23,8	25,0	26,0	26,9	27,7	28,3	29,0	29,5	[dB]
[Hz]	400	21,0	23,6	25,5	26,9	28,1	29,1	30,0	30,8	31,5	32,1	32,6	[dB]
[Hz]	500	23,9	26,5	28,4	29,8	31,0	32,0	32,9	33,7	34,4	35,0	35,5	[dB]
[Hz]	630	26,9	29,5	31,4	32,9	34,0	35,0	35,9	36,7	37,4	38,0	38,6	[dB]
[Hz]	800	30,0	32,6	34,5	36,0	37,2	38,2	39,0	39,8	40,5	41,1	41,7	[dB]
[Hz]	1000	32,9	35,5	37,4	38,9	40,1	41,1	41,9	42,7	43,4	44,0	44,6	[dB]
[Hz]	1250	35,8	38,5	40,3	41,8	43,0	44,0	44,8	45,6	46,3	46,9	47,5	[dB]
[Hz]	1600	39,0	41,7	43,5	45,0	46,2	47,2	48,1	48,8	49,5	50,1	50,7	[dB]
[Hz]	2000	41,9	44,6	46,5	47,9	49,1	50,1	51,0	51,7	52,4	53,0	53,6	[dB]
[Hz]	2500	44,8	47,5	49,4	50,8	52,0	53,0	53,9	54,6	55,3	56,0	56,5	[dB]
[Hz]	3150	47,9	50,5	52,4	53,8	55,0	56,0	56,9	57,7	58,3	59,0	59,5	[dB]

EN ISO 12354-2 Annex C - formula C.4

$$\Delta L_w = \left(13 \lg(m')\right) - \left(14,2 \lg(s')\right) + 20,8 \text{ dB}$$

EN ISO 12354-2 Annex C - formula C.1

$$\Delta L = \left(30 \lg \frac{f}{f_0}\right) \text{ dB}$$

EN ISO 12354-2 Annex C - formula C.2

$$f_0 = 160 \sqrt{\frac{s'}{m'}}$$

IMPACT NOISE INSULATION ACCORDING TO SCREED THICKNESS

A predictive study of the sound insulation of airborne and impact noise in buildings cannot be determined by calculations alone, but must be supported by experimental data and measurements in the laboratory and on site.

The acoustics laboratory at the University of Northern British Columbia is designed optimized for testing the sound insulation performance of floors in timber buildings. In fact, the receiving room is built of frame walls made of mullions and interposed rock wool insulation and OSB sheathing and two layers of gypsum board.

Impact noise assessment is measured according to ASTM E1007-15 using the impact sound machine and a sound pressure meter according to ISO. The tests involve evaluating the acoustic behavior of the floor slab according to the thickness of the screed (38 mm, 50 mm, 100 mm).

MATERIALS

- ① **X-LAM FLOOR SLABS:** The tested floor slab consists of three of 139 mm thick CLT 139V panels. Each CLT panel is 4.0 m long and 1.8 m wide. All joints are sealed with acoustic sealant and tapes. The edges between floors and walls are also sealed with acoustic sealant. The AIIc of the bare CLT floor slab is 21 ($L'_{n,w} = 89$ dB)
- ② **SILENT FLOOR PUR:** high-performance resilient agglomerate underscreed membrane made from pre-consumer industrial waste and PE vapour barrier.
- ③ **Screed:** ordinary concrete
 - thickness 38 mm, 91 kg/m²
 - thickness 50 mm, 120 kg/m²
 - thickness 100 mm, 240 kg/m²

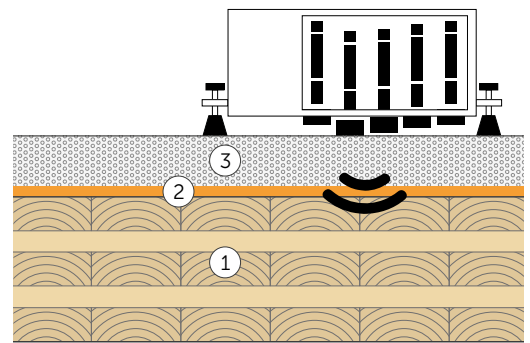

RESULTS

- CLT
- CLT + SILENT FLOOR PUR + 38 mm concrete
- CLT + SILENT FLOOR PUR + 50 mm concrete
- CLT + SILENT FLOOR PUR + 100 mm concrete

	AIIc (dBA)	$L'_{n,w}$ (dB)	Acoustic improvement (dB)
●	21	89	
●	41	69	20
●	42	68	21
●	48	62	27

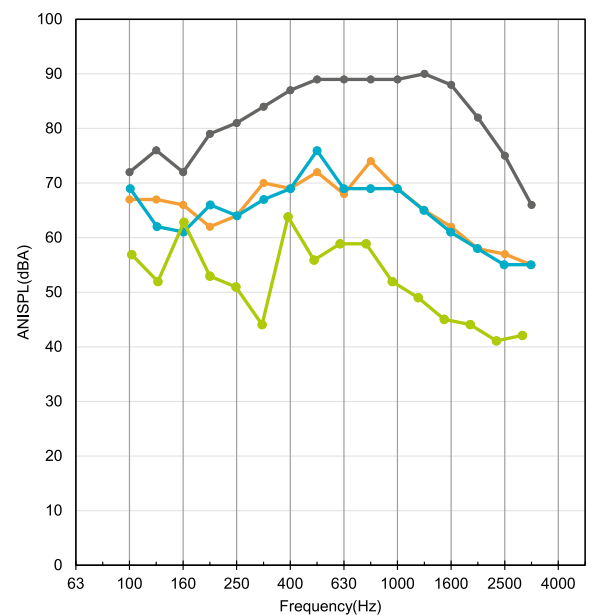

Testing laboratory: University of Northern British Columbia
 Test protocol: 20200720

LABORATORY MEASUREMENT | CLT FLOOR 1

AIRBORNE SOUND INSULATION ACCORDING TO ISO 16283-1

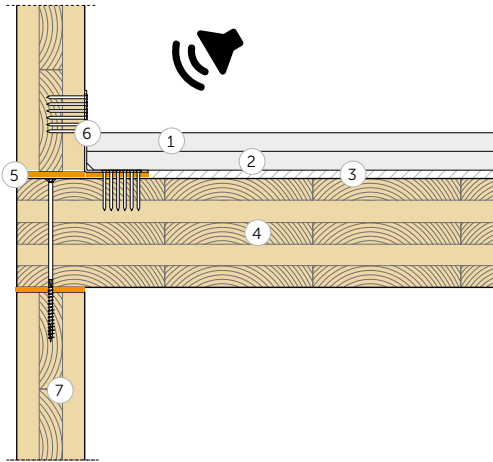

FLOOR SLAB

Surface = 21,64 m²

Mass = 167 kg/m²

Receiving room volume = 75,52 m³

- ① Reinforced gypsum-fibre board (44 kg/m²) (thickness: 32 mm)
- ② High density cardboard and sand panels (34,6 kg/m²) (thickness: 30 mm)
- ③ **SILENT FLOOR PUR - SILFLOORPUR10** (thickness: 10 mm)
- ④ CLT (thickness: 160 mm)
- ⑤ **XYLOFON 35 - XYL35100**
- ⑥ TITAN SILENT
- ⑦ CLT (thickness: 120 mm)

AIRBORNE SOUND INSULATION

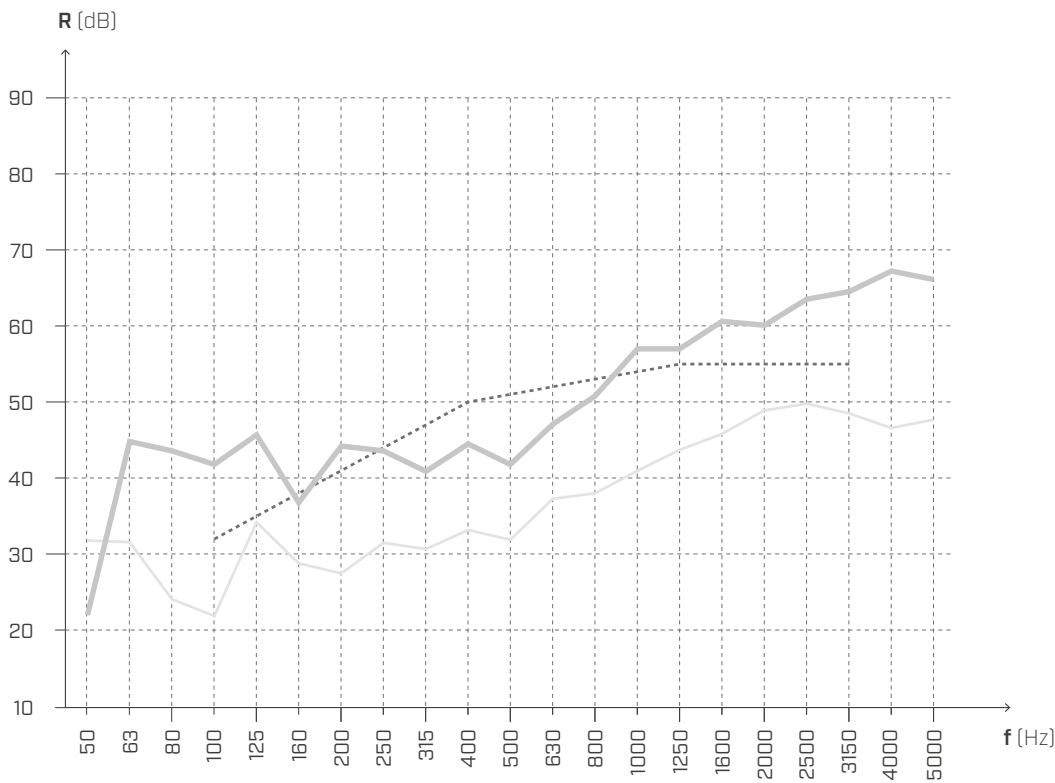

f [Hz]	R [dB]
50	22,0
63	44,8
80	43,6
100	41,8
125	45,7
160	36,8
200	44,2
250	43,6
315	40,9
400	44,5
500	41,8
630	47,1
800	50,8
1000	57,0
1250	57,0
1600	60,6
2000	60,1
2500	63,5
3150	64,5
4000	67,2
5000	66,1

— R ····· ISO 717-1 — STRUCTURE WITHOUT LAYERS no. 1, 2, 3

$$R'_w(C;C_{tr}) = \mathbf{51 (0;-6) dB}$$

$$STC = \mathbf{51}$$

$$\Delta R'_w = +12 \text{ dB}^{(1)}$$

$$\Delta STC = +12^{(1)}$$

Testing laboratory: Universität Innsbruck Arbeitsbereich für Holzbau
Technikerstraße 13A - 6020 Innsbruck.
Test protocol: M07B_L211217_m-Bodenaufbau

NOTES:

⁽¹⁾ Increase due to the addition of layers no. 1, 2 and 3.

LABORATORY MEASUREMENT | CLT FLOOR 1

IMPACT SOUND INSULATION ACCORDING TO ISO 16283-1

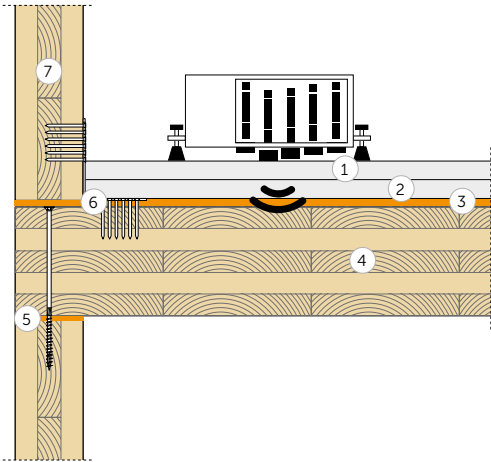

Surface = 21,64 m²
 Mass = 167 kg/m²
 Receiving room volume = 75,52 m³

- ① Reinforced gypsum-fibre board (44 kg/m²) (thickness: 32 mm)
- ② high density cardboard and sand panels (34,6 kg/m²), (thickness: 30 mm)
- ③ **SILENT FLOOR PUR- SILFLOORPUR10** (s: 10 mm)
- ④ CLT (thickness: 160 mm)
- ⑤ **XYLOFON 35 - XYL35100**
- ⑥ TITAN SILENT
- ⑦ CLT (thickness: 120 mm)

Impact sound NOISE INSULATION



f [Hz]	Ln [dB]
50	75,7
63	61,7
80	59,9
100	70,3
125	70
160	70,8
200	70
250	66,5
315	65
400	65,4
500	62,8
630	60,3
800	59,2
1000	54,3
1250	49,3
1600	45
2000	41,7
2500	38,2
3150	36,6
4000	34,3
5000	28,5

$L'_{n,w}(C_I) = 62 (0) \text{ dB}$

IIC = 48

$\Delta L_{n,w}(C_I) = -22 \text{ dB}^{(1)}$

$\Delta \text{IIC} = +22^{(2)}$

Testing laboratory: Universität Innsbruck Arbeitsbereich für Holzbau
 Technikerstraße 13A - 6020 Innsbruck.
Test protocol: M07B_T211217_m-Bodenaufbau

NOTES:
⁽¹⁾ Decrease due to the addition of layers no. 1 and no. 2.
⁽²⁾ Increase due to the addition of layers no. 1 and no. 2.

LABORATORY MEASUREMENT | CLT FLOOR 2

MEASUREMENT OF AIRBORNE SOUND INSULATION EVALUATION INDEX

REFERENCE STANDARD ISO 10140-2

FLOOR SLAB

Surface = 12 m²
 Mass = 230 kg/m²
 Receiving room volume = 54,7 m³

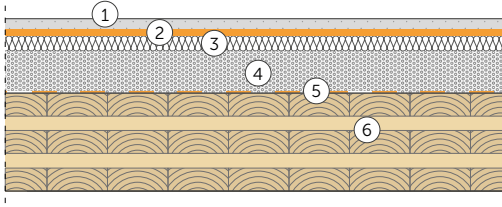

- ① Concrete screed (2000 kg/m³) (thickness: 50 mm)
- ② **SILENT FLOOR PUR** (thickness: 10 mm)
- ③ Mineral wool insulation $s' \leq 10 \text{ MN/m}^3$ (110 kg/m³) (thickness 40 mm)
- ④ Light screed with EPS (500 kg/m³) (thickness: 120 mm)
- ⑤ **BARRIER SD150**
- ⑥ CLT 5 layers (thickness: 150 mm)

AIRBORNE SOUND INSULATION

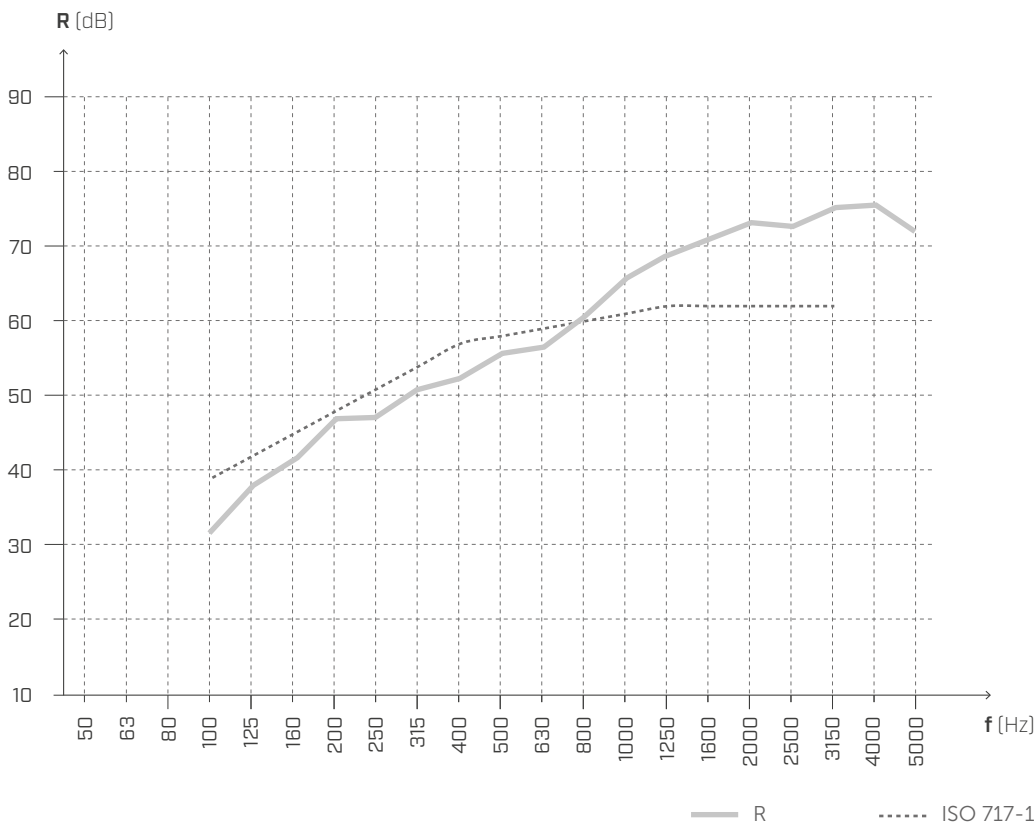

f [Hz]	R [dB]
50	-
63	-
80	-
100	30,7
125	37,1
160	40,8
200	46,3
250	46,1
315	49,5
400	51,6
500	54,4
630	55,7
800	59,6
1000	64,5
1250	67,6
1600	69,8
2000	72,1
2500	71,8
3150	74,1
4000	74,5
5000	71,1

R_w = 57 (-2;-9) dB

STC = 57

Testing laboratory: Alma Mater Studiorum Università di Bologna
 Test protocol: 01L/RothoB

LABORATORY MEASUREMENT | CLT FLOOR 2

MEASUREMENT OF THE EVALUATION INDEX OF THE REDUCTION OF THE IMPACT SOUND PRESSURE LEVEL
 REFERENCE STANDARD: ISO 10140-3 AND EN ISO 717-2

FLOOR SLAB

Surface = 12 m²

Mass = 230 kg/m²

Receiving room volume = 54,7 m³

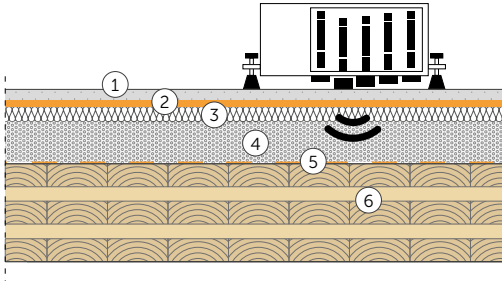

- ① Concrete screed (2000 kg/m³), (thickness: 50 mm)
- ② **SILENT FLOOR PUR** (thickness: 10 mm)
- ③ Mineral wool insulation $s' \leq 10 \text{ MN/m}^3$ (110 kg/m³), (thickness: 40 mm)
- ④ Light screed with EPS (500 kg/m³) (thickness: 120 mm)
- ⑤ **BARRIER SD150**
- ⑥ CLT 5 layers (thickness: 150 mm)

IMPACT SOUND INSULATION

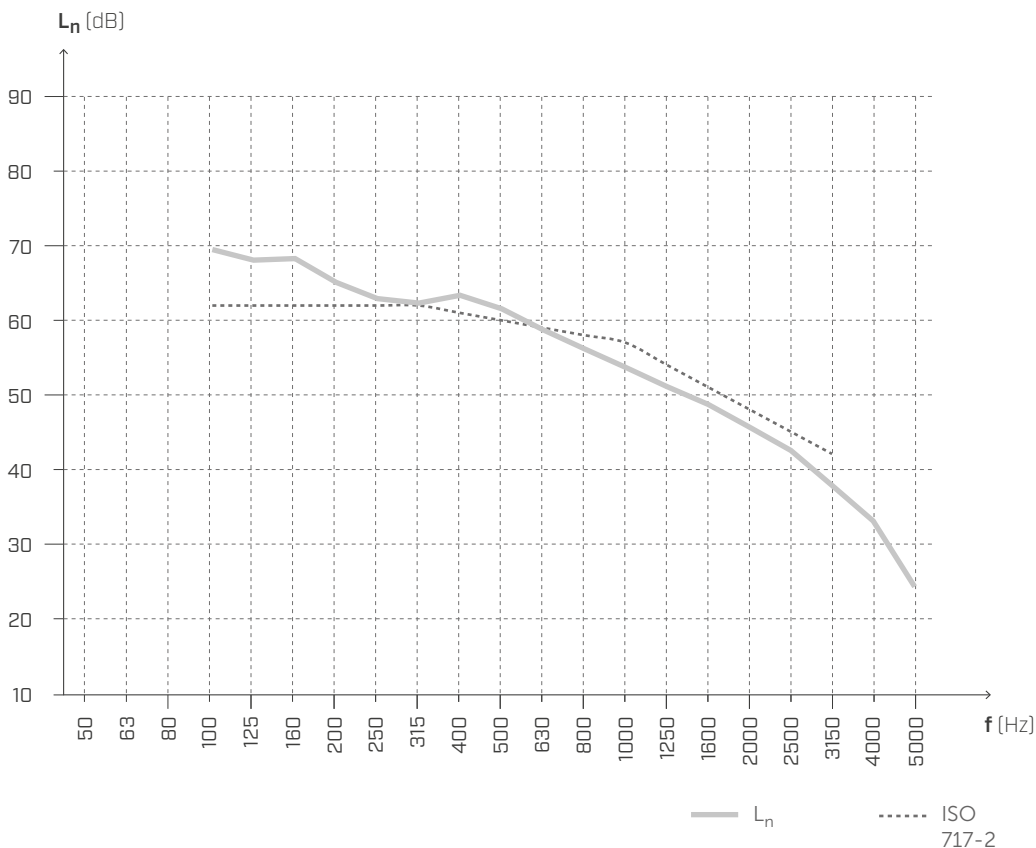

f [Hz]	Ln [dB]
50	-
63	-
80	-
100	69,5
125	68,1
160	68,3
200	65,1
250	62,9
315	62,3
400	63,4
500	61,6
630	58,7
800	56,2
1000	53,7
1250	51,1
1600	48,7
2000	45,6
2500	42,5
3150	37,8
4000	33,0
5000	24,1

$$L_{n,w}(C_I) = \mathbf{60 (0) \text{ dB}}$$

$$\mathbf{IIC = 50}$$

$$\Delta L_{n,w}(C_I) = -27 \text{ dB}^{(1)}$$

$$\Delta IIC = +27^{(2)}$$

Testing laboratory: Alma Mater Studiorum Università di Bologna
 Test protocol: 01R/RothoB

NOTES:

⁽¹⁾ Decrease due to the addition of layers no. 1 and no. 2.

⁽²⁾ Increase due to the addition of layers no. 1 and no. 2.

LABORATORY MEASUREMENT | CLT FLOOR 3

MEASUREMENT OF THE EVALUATION INDEX OF THE REDUCTION OF THE IMPACT SOUND PRESSURE LEVEL
 REFERENCE STANDARD: ISO 10140-3 AND EN ISO 717-2

FLOOR SLAB

Surface = 13,71 m²

Surface mass = 215,1 kg/m²

Receiving room volume = 60,1 m³

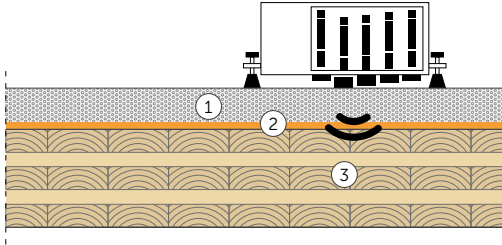

- ① Concrete screed (thickness: 50 mm); (2600 kg/m³); (130 kg/m²)
- ② SILENT FLOOR PUR - SILFLOORPUR10 (thickness: 10 mm)
- ③ CLT 5 layers (thickness: 200 mm); (420 kg/m³); (84 kg/m²)

IMPACT SOUND INSULATION



f [Hz]	L _n [dB]
50	61,6
63	61,0
80	60,7
100	71,5
125	69,9
160	70,4
200	70,6
250	67,8
315	67,0
400	64,9
500	61,5
630	60,1
800	58,8
1000	56,9
1250	56,1
1600	54,8
2000	55,5
2500	55,5
3150	55,6
4000	51,8
5000	44,5

$$L_{n,w}(C_I) = 65 (-2) \text{ dB}$$

$$IIC = 44$$

$$\Delta L_{n,w}(C_I) = -21 \text{ dB}^{(1)}$$

$$\Delta IIC = +20^{(2)}$$

Testing laboratory: Building Physics Lab | Libera Università di Bolzano.

Test protocol: Pr. 2022-rothoLATE-L2.

NOTES:

⁽¹⁾ Decrease due to the addition of layers no. 1 and no. 2.

⁽²⁾ Increase due to the addition of layers no. 1 and no. 2.

LABORATORY MEASUREMENT | CLT FLOOR 3

MEASUREMENT OF THE EVALUATION INDEX OF THE REDUCTION OF THE IMPACT SOUND PRESSURE LEVEL
RUBBER BALL METHOD | REFERENCE STANDARD: ISO 10140-3 AND EN ISO 717-2

FLOOR SLAB

Surface = 13,71 m²

Surface mass = 215,1 kg/m²

Receiving room volume = 60,1 m³

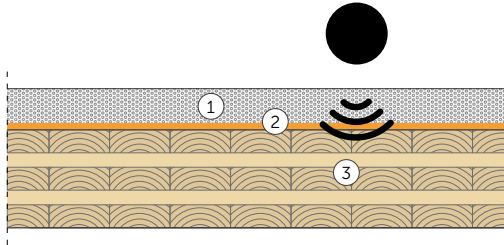

- ① Concrete screed (thickness: 50 mm); (2600 kg/m³); (130 kg/m²)
- ② SILENT FLOOR PUR - SILFLOORPUR10 (thickness: 10 mm)
- ③ CLT 5 layers (thickness: 200 mm); (420 kg/m³); (84 kg/m²)

IMPACT SOUND INSULATION

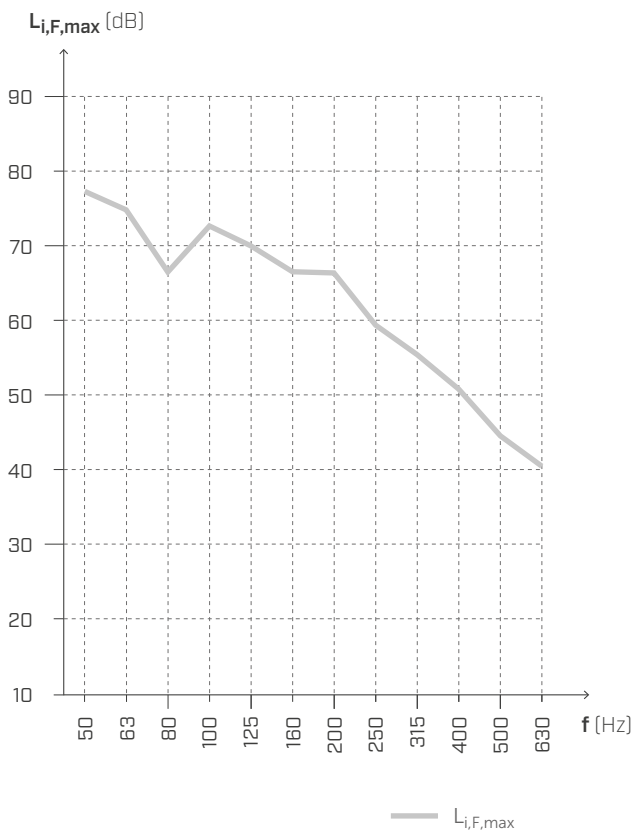

f [Hz]	L _{i,F,max} [dB]
50	77,3
63	74,8
80	66,5
100	72,7
125	70,0
160	66,5
200	66,3
250	59,4
315	55,4
400	50,8
500	44,5
630	40,4

Testing laboratory: Building Physics Lab | Libera Università di Bolzano.
Test protocol: Pr. 2022-rothoLATE-L2.

LABORATORY MEASUREMENT | FRAME WALL 4A

MEASUREMENT OF AIRBORNE SOUND INSULATION EVALUATION INDEX

REFERENCE STANDARD: ISO 10140-2 AND EN ISO 717-1

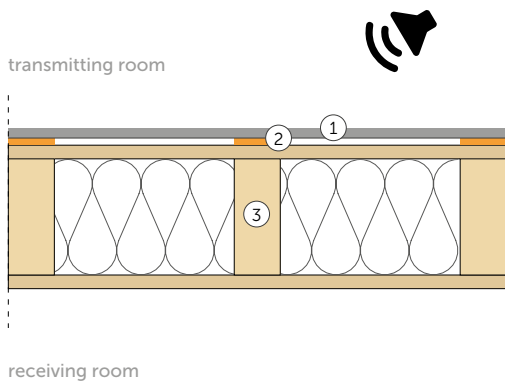

WALL

Surface = 10,16 m²
 Surface mass = 33,6 kg/m²
 Receiving room volume = 60,6 m³

- ① Plasterboard (thickness: 12,5 mm); (720 kg/m³); (9 kg/m²)
- ② SILENT FLOOR PUR - SILFLOORPUR10 strips (thickness: 10 mm)
- ③ Timber frame (thickness: 170 mm)
 timber struts 60 x 140 mm - spacing 600 mm
 2x rock wool (thickness: 60mm), (70 kg/m³)
 OSB (thickness: 15 mm), (550 kg/m³)

AIRBORNE SOUND INSULATION

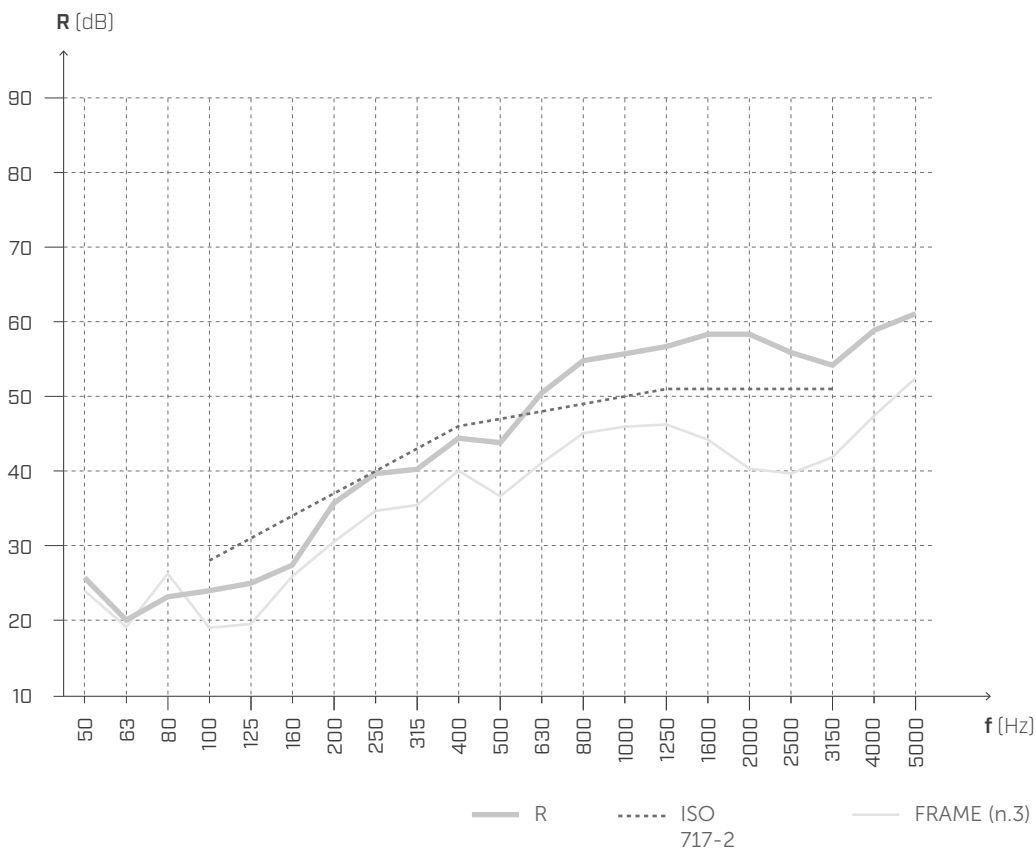

f [Hz]	R [dB]
50	25,7
63	20,1
80	23,2
100	24,0
125	25,0
160	27,4
200	35,7
250	39,7
315	40,3
400	44,4
500	43,8
630	50,5
800	54,8
1000	55,7
1250	56,7
1600	58,3
2000	58,3
2500	55,9
3150	54,2
4000	58,9
5000	61,1

$$R_w(C;C_{tr}) = 47 (-2; -8) \text{ dB}$$

$$STC = 48$$

$$\Delta R_w = +6 \text{ dB}^{(1)}$$

$$\Delta STC = +7^{(1)}$$

Testing laboratory: Building Physics Lab | Libera Università di Bolzano.
 Test protocol: Pr. 2022-rothoLATE-R6a.

NOTES:

⁽¹⁾ Increase due to the addition of layers no. 1 and no. 2.

LABORATORY MEASUREMENT | CLT FLOOR 4B

MEASUREMENT OF AIRBORNE SOUND INSULATION EVALUATION INDEX

REFERENCE STANDARD: ISO 10140-2 AND EN ISO 717-1

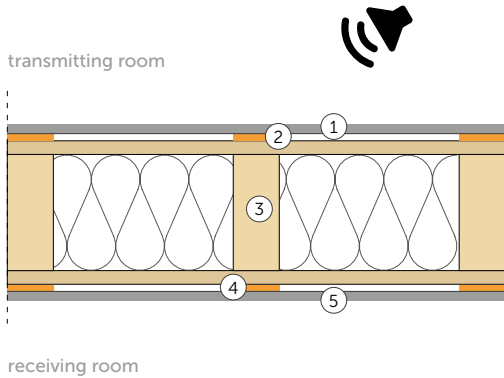

WALL

Surface = 10,16 m²
 Surface mass = 42,9 kg/m²
 Receiving room volume = 60,6 m³

- ① Plasterboard (thickness: 12,5 mm); (720 kg/m³); (9 kg/m²)
- ② SILENT FLOOR PUR - SILFLOORPUR10 strips (thickness: 10 mm)
- ③ Timber frame (thickness: 170 mm)
 timber struts 60 x 140 mm - spacing 600 mm
 2x rock wool (thickness: 60mm), (70 kg/m³)
 OSB (thickness: 15 mm), (550 kg/m³)
- ④ SILENT FLOOR PUR - SILFLOORPUR10 strips (thickness: 10 mm)
- ⑤ Plasterboard (thickness: 12,5 mm); (720 kg/m³); (9 kg/m²)

AIRBORNE SOUND INSULATION



f [Hz]	R [dB]
50	24,9
63	21,6
80	21,0
100	24,8
125	27,6
160	30,4
200	39,8
250	41,9
315	44,4
400	48,8
500	50,3
630	57,6
800	61,0
1000	63,6
1250	65,5
1600	66,8
2000	66,7
2500	64,4
3150	60,0
4000	63,1
5000	62,5

$$R_w(C;C_{tr}) = 51 (-3;-10) \text{ dB}$$

$$\Delta R_w = +10 \text{ dB}^{(1)}$$

$$STC = 51$$

$$\Delta STC = +10^{(1)}$$

Testing laboratory: Building Physics Lab | Libera Università di Bolzano.

Test protocol: Pr. 2022-rothoLATE-R6b.

NOTES:

⁽¹⁾ Increase due to the addition of layers no. 1 and no. 2.

LABORATORY MEASUREMENT | FRAME WALL 5A

MEASUREMENT OF AIRBORNE SOUND INSULATION EVALUATION INDEX

REFERENCE STANDARD: ISO 10140-2 AND EN ISO 717-1

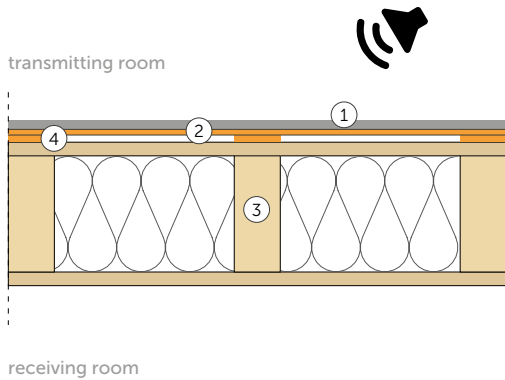

WALL

Surface = 10,16 m²
 Surface mass = 38,6 kg/m²
 Receiving room volume = 60,6 m³

- ① Plasterboard (thickness: 12,5 mm); (720 kg/m³); (9 kg/m²)
- ② SILENT WALL BYTUM SA (thickness: 4 mm), (1250 kg/m³), 5 kg/m²)
- ③ SILENT FLOOR PUR - SILFLOORPUR10 strips (thickness: 10 mm)
- ④ Timber frame (thickness: 170 mm)
 timber struts 60 x 140 mm - spacing 600 mm
 2x rock wool (thickness: 60mm), (70 kg/m³)
 OSB (thickness: 15 mm), (550 kg/m³)

AIRBORNE SOUND INSULATION

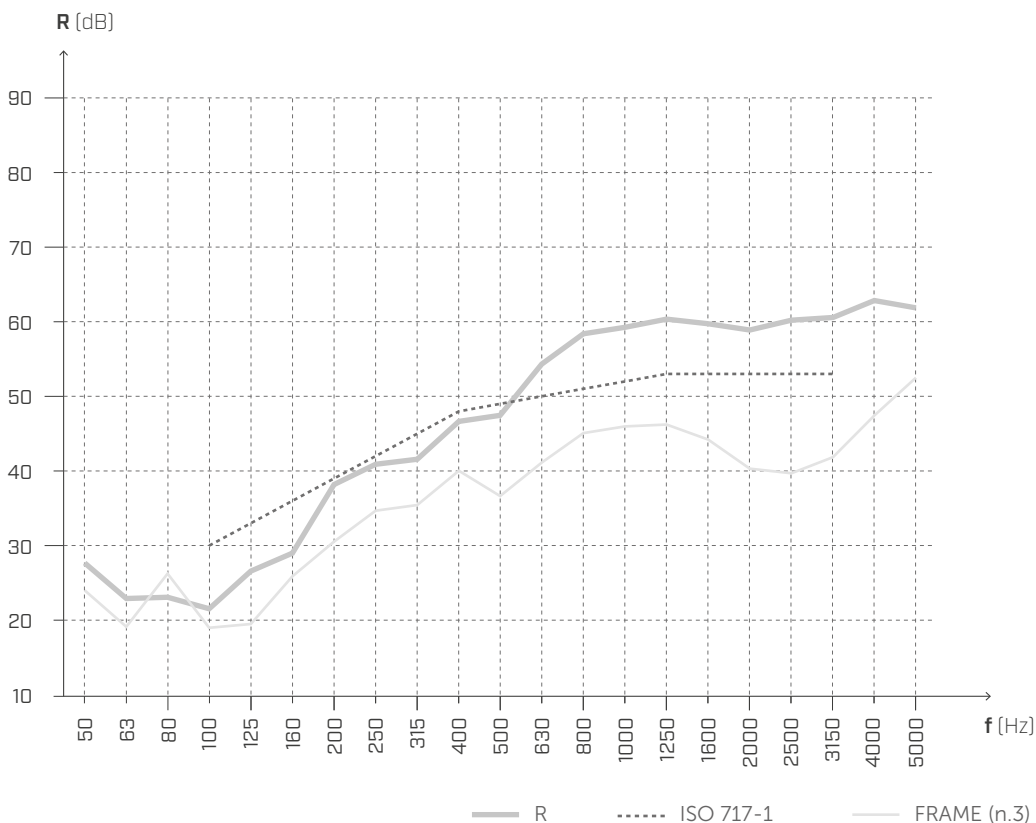

f [Hz]	R [dB]
50	27,7
63	22,9
80	23,1
100	21,6
125	26,6
160	29,0
200	38,2
250	40,9
315	41,6
400	46,7
500	47,5
630	54,3
800	58,4
1000	59,2
1250	60,3
1600	59,7
2000	58,9
2500	60,2
3150	60,6
4000	62,8
5000	61,8

$$R_w(C;C_{tr}) = 49 (-3;-10) \text{ dB}$$

$$STC = 50$$

$$\Delta R_w = +8 \text{ dB}^{(1)}$$

$$\Delta STC = +9^{(1)}$$

Testing laboratory: Building Physics Lab | Libera Università di Bolzano.
 Test protocol: Pr. 2022-rothoLATE-R5a.

NOTES:

⁽¹⁾ Increase due to the addition of layers no. 1 and no. 2.

LABORATORY MEASUREMENT | FRAME WALL 5B

MEASUREMENT OF AIRBORNE SOUND INSULATION EVALUATION INDEX

REFERENCE STANDARD: ISO 10140-2 AND EN ISO 717-1

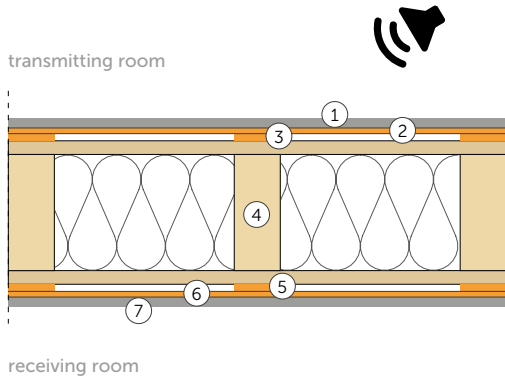

WALL

Surface = 10,16 m²
 Surface mass = 52,9 kg/m²
 Receiving room volume = 60,6 m³

- ① Plasterboard (thickness: 12,5 mm); (720 kg/m³); (9 kg/m²)
- ② SILENT WALL BYTUM SA (thickness: 4 mm), (1250 kg/m³), 5 kg/m²)
- ③ SILENT FLOOR PUR - SILFLOORPUR10 strips (thickness: 10 mm)
- ④ Timber frame (thickness: 170 mm)
 timber struts 60 x 140 mm - spacing 600 mm
 2x rock wool (thickness: 60mm), (70 kg/m³)
 OSB (thickness: 15 mm), (550 kg/m³)
- ⑤ SILENT FLOOR PUR - SILFLOORPUR10 strips (thickness: 10 mm)
- ⑥ SILENT WALL BYTUM SA (thickness: 4 mm), (1250 kg/m³), 5 kg/m²)
- ⑦ Plasterboard (thickness: 12,5 mm); (720 kg/m³); (9 kg/m²)

AIRBORNE SOUND INSULATION

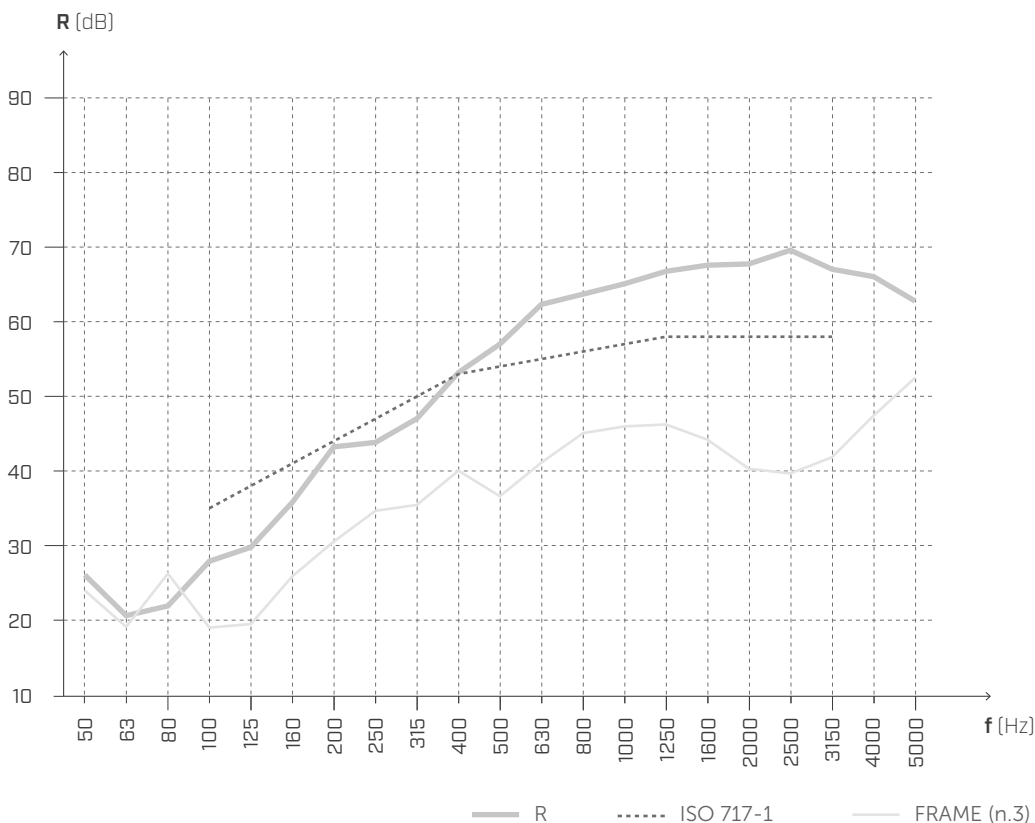

f [Hz]	R [dB]
50	26,1
63	20,6
80	21,9
100	27,9
125	29,8
160	35,8
200	43,2
250	43,8
315	47,0
400	53,2
500	57,0
630	62,3
800	63,7
1000	65,1
1250	66,8
1600	67,6
2000	67,7
2500	69,6
3150	67,0
4000	66,0
5000	62,8

$$R_w(C;C_{tr}) = 54 (-3;-9) \text{ dB}$$

$$STC = 54$$

$$\Delta R_w = +13 \text{ dB}^{(1)}$$

$$\Delta STC = +13^{(1)}$$

Testing laboratory: Building Physics Lab | Libera Università di Bolzano.

Test protocol: Pr. 2022-rothoLATE-R5b.

NOTES:

⁽¹⁾ Increase due to the addition of layers no. 1 and no. 2.

LABORATORY MEASUREMENT | FRAME WALL 6A

MEASUREMENT OF AIRBORNE SOUND INSULATION EVALUATION INDEX

REFERENCE STANDARD: ISO 10140-2 AND EN ISO 717-1

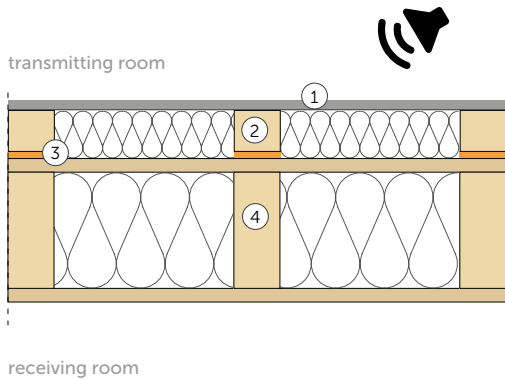

WALL

Surface = 10,16 m²
 Surface mass = 37,2 kg/m²
 Receiving room volume = 60,6 m³

- ① Plasterboard (thickness: 12,5 mm); (720 kg/m³); (9 kg/m²)
- ② Counter wall (thickness: 40 mm)
 timber battens 40 x 60 mm - spacing 600 mm
 rock wool (thickness: 40mm), (38 kg/m³)
- ③ **SILENT FLOOR PUR - SILFLOORPUR10** strips (thickness: 10 mm)
- ④ Timber frame (thickness: 170 mm)
 timber struts 60 x 140 mm - spacing 600 mm
 2x rock wool (thickness: 60mm), (70 kg/m³)
 OSB (thickness: 15 mm), (550 kg/m³)

AIRBORNE SOUND INSULATION



f [Hz]	R [dB]
50	22,9
63	18,0
80	22,1
100	23,4
125	24,2
160	32,4
200	37,5
250	42,5
315	45,8
400	48,1
500	48,9
630	54,5
800	56,1
1000	57,5
1250	58,9
1600	60,8
2000	59,9
2500	59,0
3150	58,2
4000	65,7
5000	72,2

$R_w(C;C_{tr}) = 50 (-4; -10) \text{ dB}$

$STC = 48$

$\Delta R_w = +9 \text{ dB}^{(1)}$

$\Delta STC = +7^{(1)}$

Testing laboratory: Building Physics Lab | Libera Università di Bolzano.
 Test protocol: Pr. 2022-rothoLATE-R12a.

NOTES:
⁽¹⁾ Increase due to the addition of layers no. 1 and no. 2.

LABORATORY MEASUREMENT | FRAME WALL 6B

MEASUREMENT OF AIRBORNE SOUND INSULATION EVALUATION INDEX

REFERENCE STANDARD ISO 10140-2

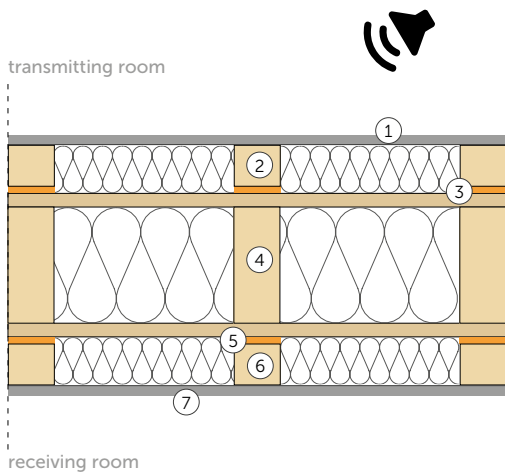

WALL

Surface = 10,16 m²
 Surface mass = 52,2 kg/m²
 Receiving room volume = 60,6 m³

- ① Plasterboard (thickness: 12,5 mm); (720 kg/m³); (9 kg/m²)
- ② Counter wall (thickness: 40 mm)
 timber battens 40 x 60 mm - spacing 600 mm;
 rock wool (thickness: 40 mm), (38 kg/m³)
- ③ SILENT FLOOR PUR - SILFLOORPUR10 strips (thickness: 10 mm)
- ④ Timber frame (thickness: 170 mm)
 timber struts 60 x 140 mm - spacing 600 mm;
 2x rock wool (thickness: 60mm), (70 kg/m³)
 OSB (thickness: 15 mm), (550 kg/m³)
- ⑤ SILENT FLOOR PUR - SILFLOORPUR10 strips (thickness: 10 mm),
 (110 kg/m³), (1,1 kg/m²)
- ⑥ Counter wall (thickness: 40 mm)
 timber battens 40 x 60 mm - spacing 600 mm;
 rock wool (thickness: 40 mm), (38 kg/m³)
- ⑦ Plasterboard (thickness: 12,5 mm); (720 kg/m³); (9 kg/m²)

AIRBORNE SOUND INSULATION

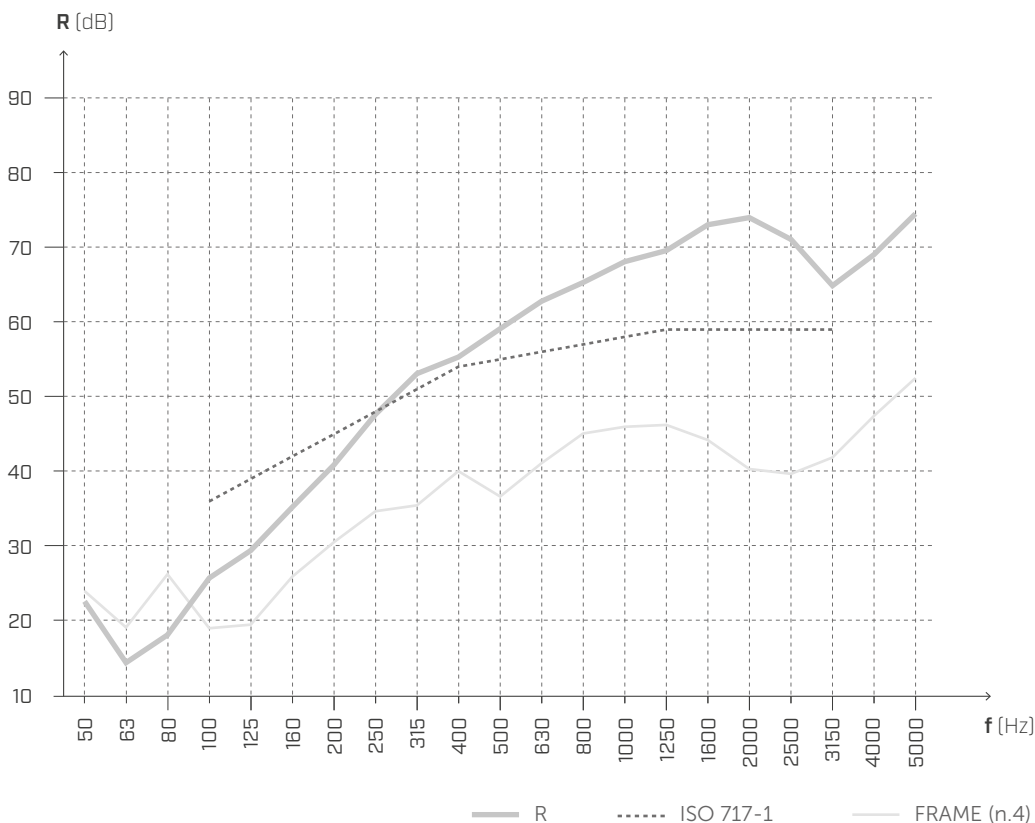

f [Hz]	R [dB]
50	22,6
63	14,4
80	18,1
100	25,7
125	29,4
160	35,2
200	40,9
250	47,6
315	53,1
400	55,3
500	59,1
630	62,8
800	65,3
1000	68,1
1250	69,6
1600	73,0
2000	74,0
2500	71,0
3150	64,9
4000	69,0
5000	74,5

$$R_w(C;C_{tr}) = 55 (-5; -12) \text{ dB}$$

$$STC = 53$$

$$\Delta R_w = +14 \text{ dB}^{(1)}$$

$$\Delta STC = +12^{(1)}$$

Testing laboratory: Building Physics Lab | Libera Università di Bolzano.
 Test protocol: Pr. 2022-rothoLATE-R12b.

NOTES:

⁽¹⁾ Increase due to the addition of layers no. 1 and no. 2.

LABORATORY MEASUREMENT | FRAME WALL 7A

MEASUREMENT OF AIRBORNE SOUND INSULATION EVALUATION INDEX

REFERENCE STANDARD: ISO 10140-2 AND EN ISO 717-1



transmitting room

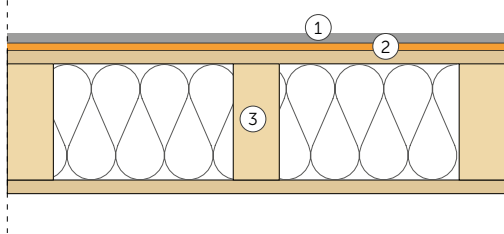

receiving room

WALL

Surface = 10,16 m²

Surface mass = 34,4 kg/m²

Receiving room volume = 60,6 m³

- ① Plasterboard (thickness: 12,5 mm); (720 kg/m³); (9 kg/m²)
- ② SILENT FLOOR PUR - SILFLOORPUR10 (thickness: 10 mm)
- ③ Timber frame (thickness: 170 mm)
 timber struts 60 x 140 mm - spacing 600 mm
 2x rock wool (thickness: 60mm), (70 kg/m³)
 OSB (thickness: 15 mm), (550 kg/m³)

AIRBORNE SOUND INSULATION



f [Hz]	R [dB]
50	23,6
63	19,9
80	24,2
100	23,3
125	24,2
160	26,4
200	34,0
250	38,7
315	40,6
400	44,8
500	46,8
630	53,6
800	59,2
1000	61,0
1250	62,3
1600	61,8
2000	59,1
2500	57,3
3150	56,2
4000	62,4
5000	68,7

$$R_w(C;C_{tr}) = 47 (-3;-9) \text{ dB}$$

$$STC = 47$$

$$\Delta R_w = +6 \text{ dB}^{(1)}$$

$$\Delta STC = +6^{(1)}$$

Testing laboratory: Building Physics Lab | Libera Università di Bolzano.

Test protocol: Pr. 2022-rothoLATE-R13a.

NOTES:

⁽¹⁾ Increase due to the addition of layers no. 1 and no. 2.

LABORATORY MEASUREMENT | FRAME WALL 7B

MEASUREMENT OF AIRBORNE SOUND INSULATION EVALUATION INDEX

REFERENCE STANDARD: ISO 10140-2 AND EN ISO 717-1



transmitting room

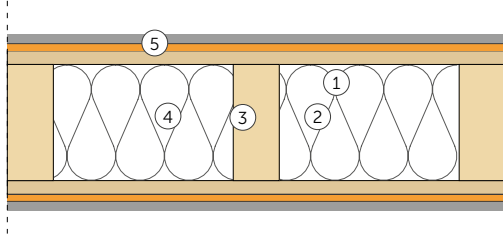

receiving room

WALL

Surface = 10,16 m²
 Surface mass = 44,5 kg/m²
 Receiving room volume = 60,6 m³

- ① Plasterboard (thickness: 12,5 mm); (720 kg/m³) (9 kg/m²)
- ② SILENT FLOOR PUR - SILFLOORPUR10 (thickness: 10 mm)
- ③ Timber frame (thickness: 170 mm)
 timber struts 60 x 140 mm - spacing 600 mm;
 2x rock wool (thickness: 60mm), (70 kg/m³)
 OSB (thickness: 15 mm), (550 kg/m³)
- ④ SILENT FLOOR PUR - SILFLOORPUR10 (thickness: 10 mm)
- ⑤ Plasterboard (thickness: 12,5 mm); (720 kg/m³) (9 kg/m²)

AIRBORNE SOUND INSULATION

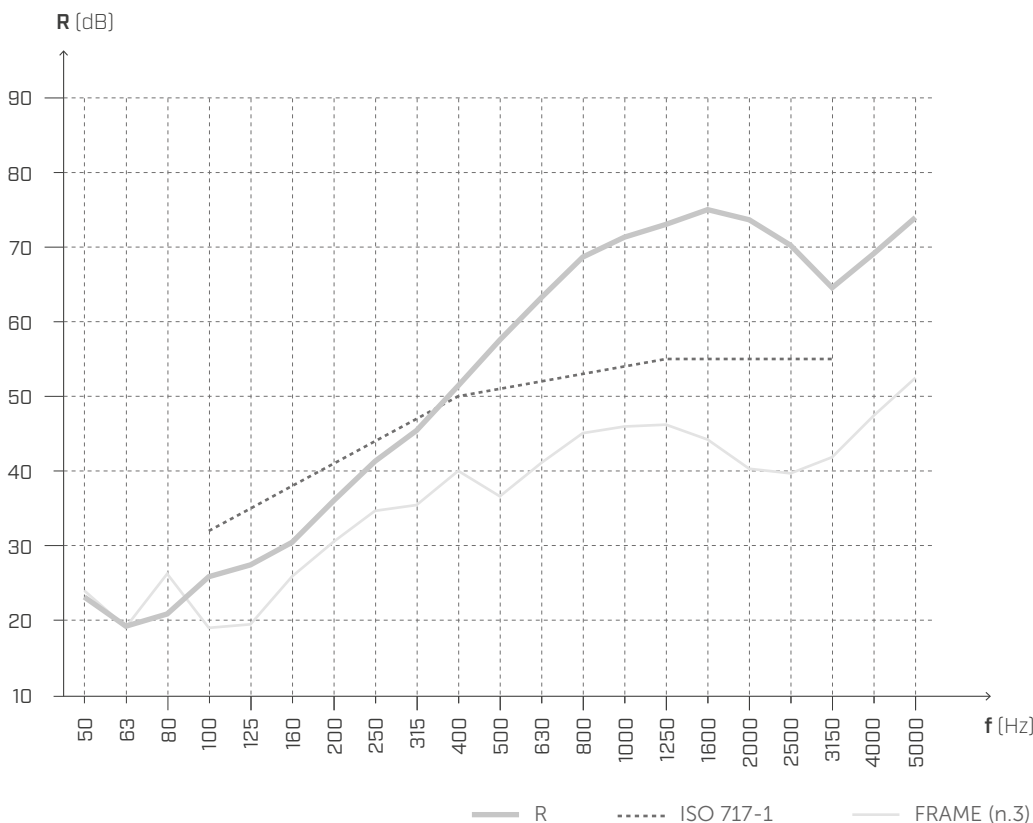

f [Hz]	R [dB]
50	23,2
63	19,3
80	20,9
100	25,9
125	27,4
160	30,5
200	36,0
250	41,3
315	45,4
400	51,4
500	57,6
630	63,2
800	68,6
1000	71,3
1250	73,0
1600	75,0
2000	73,6
2500	70,2
3150	64,5
4000	69,1
5000	73,9

$$R_w(C;C_{tr}) = 51 (-3;-9) \text{ dB}$$

$$STC = 51$$

$$\Delta R_w = +10 \text{ dB}^{(1)}$$

$$\Delta STC = +10^{(1)}$$

Testing laboratory: Building Physics Lab | Libera Università di Bolzano.

Test protocol: Pr. 2022-rothoLATE-R13b.

NOTES:

⁽¹⁾ Increase due to the addition of layers no. 1 and no. 2.

ON SITE MEASUREMENTS

COMMERCIAL BUILDING

Atlanta [USA]



The newly constructed building boasts office space, restaurants, shops, a hotel and art studios. It is a very innovative project that also uses TIMBER as a structural material. To improve the acoustic performance of the floors, SILENT FLOOR PUR was used and ALADIN was used to reduce lateral transmission.

description	commercial building covering more than 300000 sq ft
type of structure	mixed
location	Atlanta (Georgia, USA)
products	SILENT FLOOR PUR, ALADIN

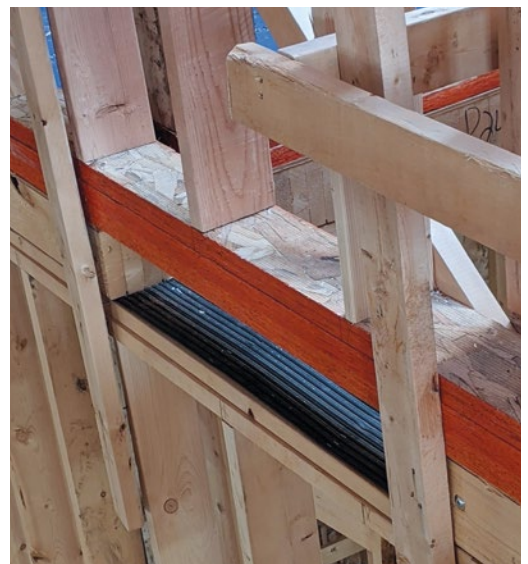

SILFLOORPUR15

TECHNICAL DATA

Properties	standard	value
Surface mass m	-	1,4 kg/m ²
Density ρ	-	90 kg/m ³
Apparent dynamic stiffness s' _t	EN 29052-1	8,8 MN/m ³
Dynamic stiffness s'	EN 29052-1	8,8 MN/m ³
Theoretical estimate of impact sound pressure level attenuation ΔL _w ⁽¹⁾	ISO 12354-2	34,6 dB
System resonance frequency f ₀ ⁽²⁾	ISO 12354-2	42,5 Hz
Impact sound pressure level attenuation ΔL _w ⁽³⁾	ISO 10140-3	23 dB
Thermal resistance R _t	-	0,52 m ² K/W
Resistance to airflow r	ISO 9053	< 10,0 kPa·s·m ⁻²
Compressibility class	EN 12431	CP2
CREEP Viscous sliding under compression X _{ct} (1,5 kPa)	EN 1606	7,50 %
Compression deformation stress	ISO 3386-1	17 kPa
Thermal conductivity λ	-	0,035 W/m·K
Specific heat c	-	1800 J/kg·K
Water vapour transmission Sd	-	> 100 m
Reaction to fire	EN 13501-1	class F
VOC emission classification	French decree no. 2011-321	A+

⁽¹⁾ΔL_w = (13 lg(m')) - (14,2 lg(s')) + 20,8 [dB] con m' = 125 kg/m².

⁽²⁾f₀ = 160 √(s'/m') con m' = 125 kg/m².

⁽³⁾Measured in the laboratory on 200 mm CLT floor. See the manual for more information on configuration.

EN ISO 12354-2 ANNEX C | ESTIMATE ΔL_w (FORMULA C.4) E ΔL (FORMULA C.1)

The following tables show how the attenuation in dB (ΔL_w e ΔL) of SILFLOORPUR15 varies as the load m' (i.e., the surface mass of the layers with which SILFLOORPUR15 is loaded) changes.

SILFLOORPUR15

s't or s'	8,8	8,8	8,8	8,8	8,8	8,8	8,8	8,8	8,8	8,8	8,8	8,8	[MN/m ³]
load m'	50	75	100	125	150	175	200	225	250	275	300		[kg/m ²]
ΔL _w	29,5	31,8	33,4	34,6	35,7	36,5	37,3	38,0	38,6	39,1	39,6		[dB]
f ₀	67,1	54,8	47,5	42,5	38,8	35,9	33,6	31,6	30,0	28,6	27,4		[Hz]

ΔL in frequency

[Hz]	100	5,2	7,8	9,7	11,2	12,4	13,4	14,2	15,0	15,7	16,3	16,9	[dB]
[Hz]	125	8,1	10,7	12,6	14,1	15,3	16,3	17,1	17,9	18,6	19,2	19,8	[dB]
[Hz]	160	11,3	14,0	15,8	17,3	18,5	19,5	20,3	21,1	21,8	22,4	23,0	[dB]
[Hz]	200	14,2	16,9	18,7	20,2	21,4	22,4	23,3	24,0	24,7	25,3	25,9	[dB]
[Hz]	250	17,1	19,8	21,6	23,1	24,3	25,3	26,2	26,9	27,6	28,2	28,8	[dB]
[Hz]	315	20,1	22,8	24,7	26,1	27,3	28,3	29,2	29,9	30,6	31,2	31,8	[dB]
[Hz]	400	23,3	25,9	27,8	29,2	30,4	31,4	32,3	33,1	33,7	34,4	34,9	[dB]
[Hz]	500	26,2	28,8	30,7	32,1	33,3	34,3	35,2	36,0	36,6	37,3	37,8	[dB]
[Hz]	630	29,2	31,8	33,7	35,1	36,3	37,3	38,2	39,0	39,7	40,3	40,8	[dB]
[Hz]	800	32,3	34,9	36,8	38,3	39,4	40,4	41,3	42,1	42,8	43,4	44,0	[dB]
[Hz]	1000	35,2	37,8	39,7	41,2	42,4	43,4	44,2	45,0	45,7	46,3	46,9	[dB]
[Hz]	1250	38,1	40,7	42,6	44,1	45,3	46,3	47,1	47,9	48,6	49,2	49,8	[dB]
[Hz]	1600	41,3	44,0	45,8	47,3	48,5	49,5	50,3	51,1	51,8	52,4	53,0	[dB]
[Hz]	2000	44,2	46,9	48,7	50,2	51,4	52,4	53,3	54,0	54,7	55,3	55,9	[dB]
[Hz]	2500	47,1	49,8	51,6	53,1	54,3	55,3	56,2	56,9	57,6	58,2	58,8	[dB]
[Hz]	3150	50,1	52,8	54,7	56,1	57,3	58,3	59,2	59,9	60,6	61,2	61,8	[dB]

EN ISO 12354-2 Annex C - formula C.4

$$\Delta L_w = \left(13 \lg(m') \right) - \left(14,2 \lg(s') \right) + 20,8 \text{ dB}$$

EN ISO 12354-2 Annex C - formula C.1

$$\Delta L = \left(30 \lg \frac{f}{f_0} \right) \text{ dB}$$

EN ISO 12354-2 Annex C - formula C.2

$$f_0 = 160 \sqrt{\frac{s'}{m'}}$$

LABORATORY MEASUREMENT | CLT FLOOR 1

MEASUREMENT OF THE EVALUATION INDEX OF THE REDUCTION OF THE IMPACT SOUND PRESSURE LEVEL
 REFERENCE STANDARD: ISO 10140-3 AND EN ISO 717-2

FLOOR SLAB

Surface = 13,71 m²

Surface mass = 215,7 kg/m²

Receiving room volume = 60,1 m³

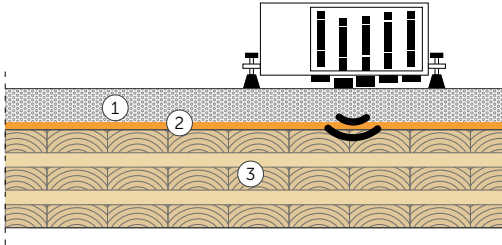

- ① Concrete screed (thickness: 50 mm); (2600 kg/m³); (130 kg/m²)
- ② SILENT FLOOR PUR - SILFLOORPUR15 (thickness: 15 mm)
- ③ CLT 5 layers (thickness: 200 mm); (420 kg/m³); (84 kg/m²)

IMPACT SOUND INSULATION



f [Hz]	L _n [dB]
50	62,7
63	63,1
80	64,0
100	70,6
125	67,3
160	64,6
200	66,9
250	63,9
315	62,4
400	60,5
500	58,3
630	56,9
800	56,2
1000	54,0
1250	53,2
1600	53,5
2000	56,4
2500	54,3
3150	50,0
4000	46,0
5000	40,7

$$L_{n,w}(C_l) = \mathbf{63 (-3) dB}$$

$$\Delta L_{n,w} = -23 \text{ dB}^{(1)}$$

$$IIC = \mathbf{47}$$

$$\Delta IIC = +23^{(2)}$$

Testing laboratory: Building Physics Lab | Libera Università di Bolzano.

Test protocol: Pr. 2022-rothoLATE-L6.

NOTES:

⁽¹⁾ Decrease due to the addition of layers no. 1 and no. 2.

⁽²⁾ Increase due to the addition of layers no. 1 and no. 2.

LABORATORY MEASUREMENT | CLT FLOOR 1

MEASUREMENT OF THE EVALUATION INDEX OF THE REDUCTION OF THE IMPACT SOUND PRESSURE LEVEL
RUBBER BALL METHOD | REFERENCE STANDARD: ISO 16283-2

FLOOR SLAB

Surface = 13,71 m²

Surface mass = 215,7 kg/m²

Receiving room volume = 60,1 m³

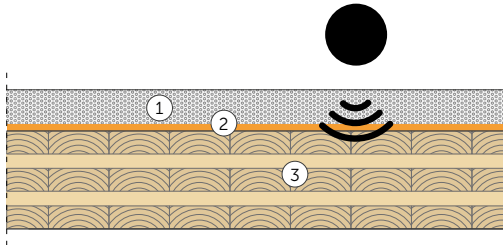

- ① Concrete screed (thickness: 50 mm); (2600 kg/m³); (130 kg/m²)
- ② SILENT FLOOR PUR - SILFLOORPUR15 (thickness: 15 mm)
- ③ CLT 5 layers (thickness: 200 mm); (420 kg/m³); (84 kg/m²)

IMPACT SOUND INSULATION

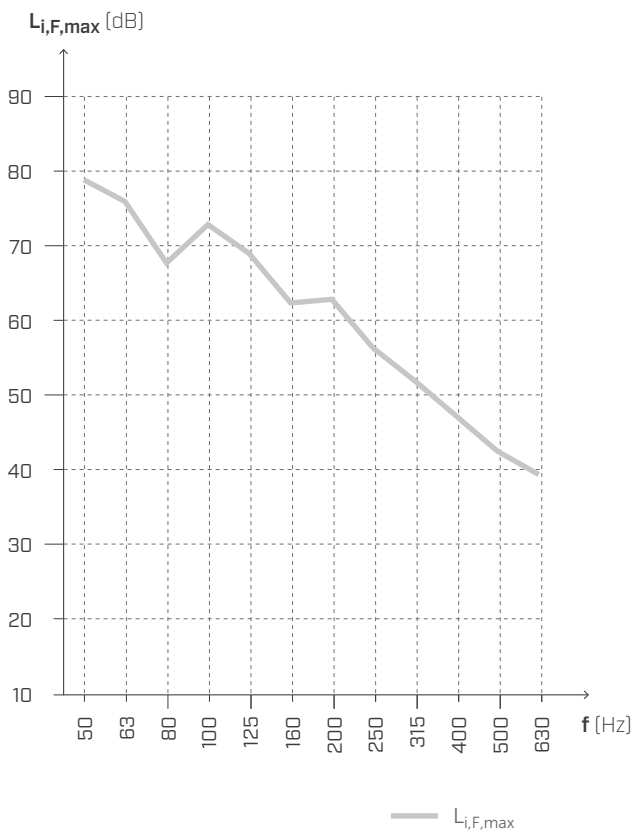

f [Hz]	L _{i,F,max} [dB]
50	78,8
63	75,9
80	67,7
100	72,8
125	68,9
160	62,3
200	62,8
250	56,3
315	51,9
400	47,2
500	42,5
630	39,4

Testing laboratory: Building Physics Lab | Libera Università di Bolzano.
Test protocol: Pr. 2022-rothoLATE-L6.

LABORATORY MEASUREMENT | CLT FLOOR 2

MEASUREMENT OF THE EVALUATION INDEX OF THE REDUCTION OF THE IMPACT SOUND PRESSURE LEVEL
 REFERENCE STANDARD: ISO 10140-3 AND EN ISO 717-2

FLOOR SLAB

Surface = 13,71 m²

Surface mass = 217,3 kg/m²

Receiving room volume = 60,1 m³

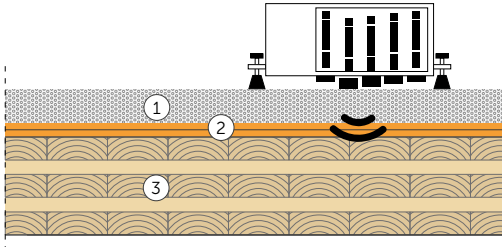

- ① Concrete screed (thickness: 50 mm); (2600 kg/m³); (130 kg/m²)
- ② 2x SILENT FLOOR PUR - SILFLOORPUR15 (thickness: 15 mm)
- ③ CLT 5 layers (thickness: 200 mm); (420 kg/m³); (84 kg/m²)

IMPACT SOUND INSULATION

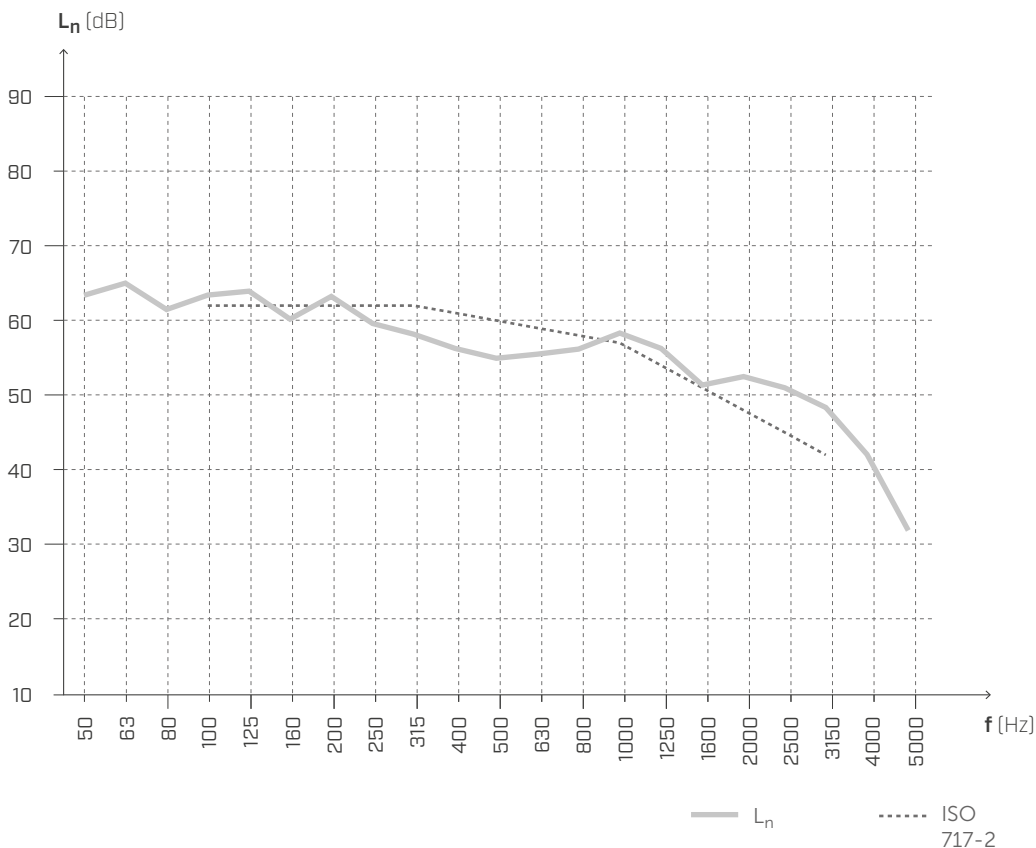

f [Hz]	L _n [dB]
50	63,4
63	65,0
80	61,5
100	63,4
125	63,9
160	60,2
200	63,2
250	59,6
315	58,2
400	56,3
500	55,0
630	55,5
800	56,2
1000	58,3
1250	56,3
1600	51,3
2000	52,5
2500	51,0
3150	48,4
4000	42,1
5000	31,9

$$L_{n,w}(C_l) = 60 (-4) \text{ dB}$$

$$\Delta L_{n,w} = -26 \text{ dB}^{(1)}$$

$$IIC = 50$$

$$\Delta IIC = +26^{(2)}$$

Testing laboratory: Building Physics Lab | Libera Università di Bolzano.

Test protocol: Pr. 2022-rothoLATE-L6.

NOTES:

⁽¹⁾ Decrease due to the addition of layers no. 1 and no. 2.

⁽²⁾ Increase due to the addition of layers no. 1 and no. 2.

LABORATORY MEASUREMENT | CLT FLOOR 2

MEASUREMENT OF THE EVALUATION INDEX OF THE REDUCTION OF THE IMPACT SOUND PRESSURE LEVEL
RUBBER BALL METHOD | REFERENCE STANDARD: ISO 16283-2

FLOOR SLAB

Surface = 13,71 m²

Surface mass = 217,3 kg/m²

Receiving room volume = 60,1 m³

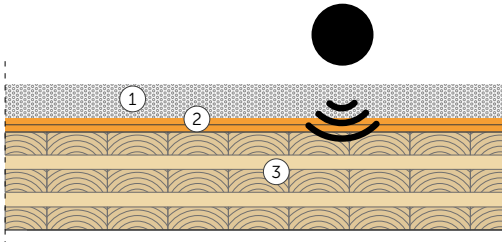

- ① Concrete screed (thickness: 50 mm); (2600 kg/m³); (130 kg/m²)
- ② 2x SILENT FLOOR PUR - SILFLOORPUR15 (thickness: 15 mm)
- ③ CLT 5 layers (thickness: 200 mm); (420 kg/m³); (84 kg/m²)

IMPACT SOUND INSULATION

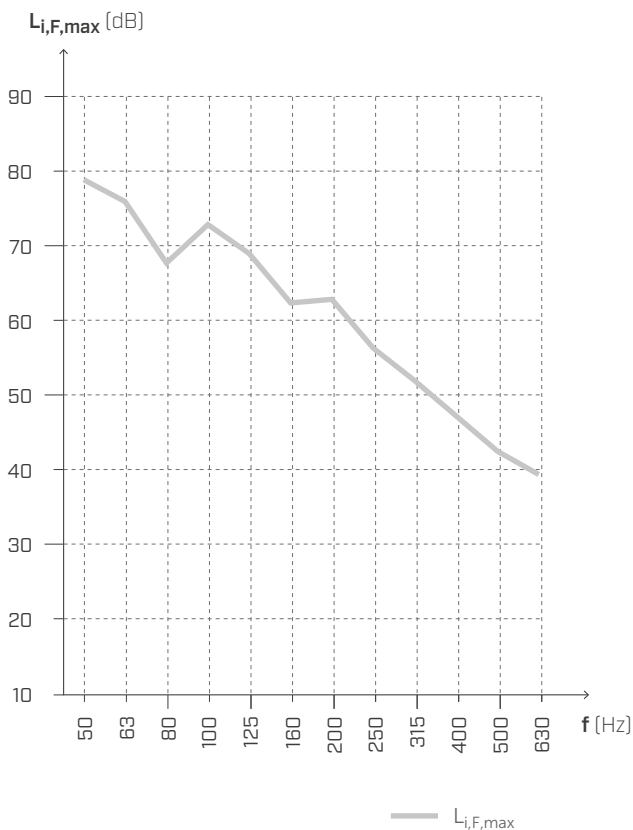

f [Hz]	L _{i,F,max} [dB]
50	81,5
63	79,0
80	68,2
100	65,2
125	63,5
160	57,8
200	59,6
250	52,9
315	48,5
400	44,3
500	40,7
630	38,0

Testing laboratory: Building Physics Lab | Libera Università di Bolzano.
Test protocol: Pr. 2022-rothoLATE-L6.

CERTAIN COLLABORATIONS ARE BORN TO LAST

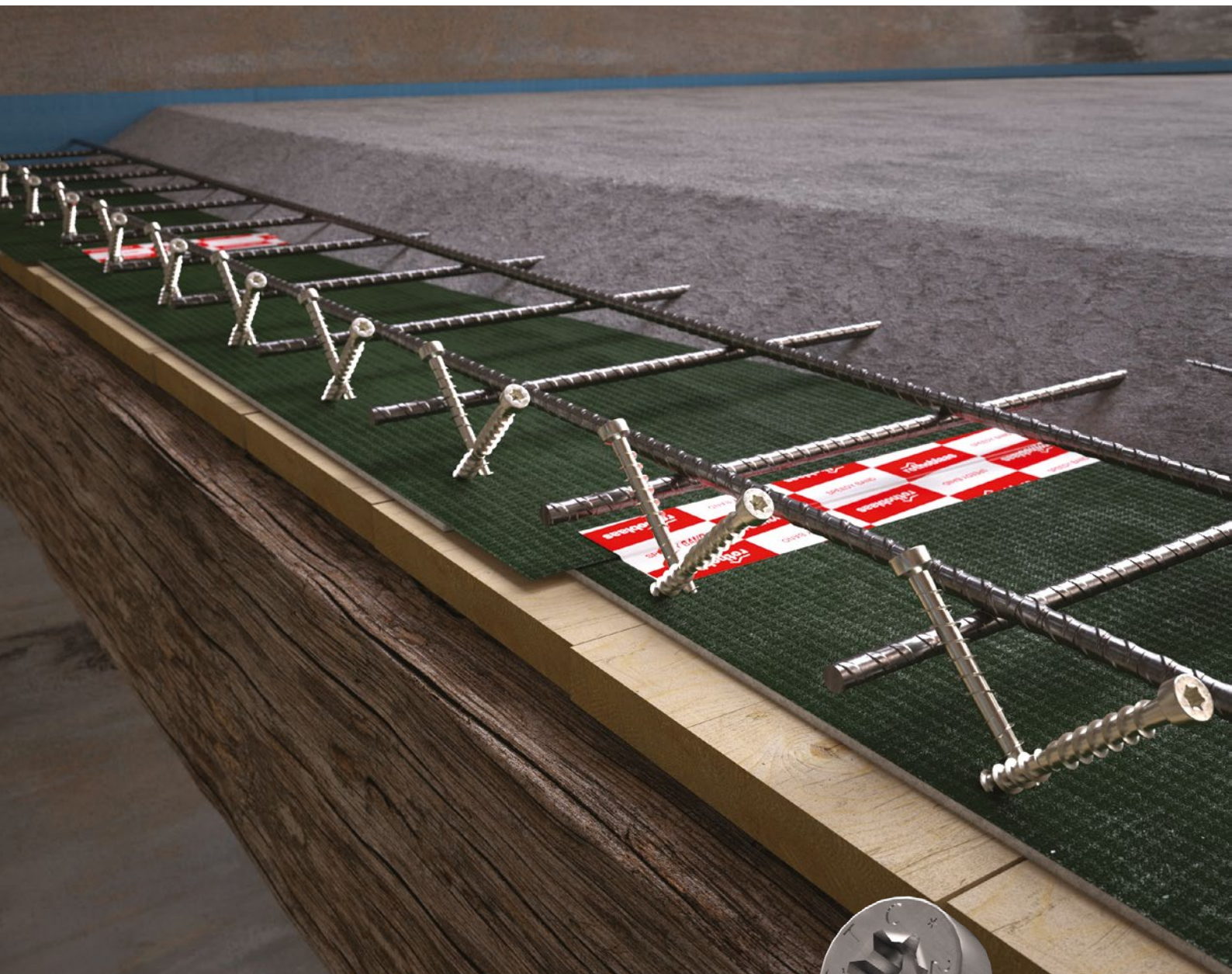

CTC is the connector for timber-to-concrete floors. CE certified, it allows to connect a 5 or 6 cm reinforced concrete slab to the timber beams of the underneath floor, obtaining a new timber-concrete structure with extraordinary strength and excellent static and acoustic performance. It is an approved self-drilling, reversible, fast and minimally invasive system.

Scan the QR code and discover the technical features of CTC connector



www.rothoblaas.com

**rothoblaas**

Solutions for Building Technology

SILFLOORPUR20

TECHNICAL DATA

Properties	standard	value
Surface mass m	-	1,8 kg/m ²
Density ρ	-	90 kg/m ³
Apparent dynamic stiffness s' _t	EN 29052-1	7,4 MN/m ³
Dynamic stiffness s'	EN 29052-1	7,4 MN/m ³
Theoretical estimate of impact sound pressure level attenuation ΔL _w ⁽¹⁾	ISO 12354-2	35,7 dB
System resonance frequency f ₀ ⁽²⁾	ISO 12354-2	38,9 Hz
Impact sound pressure level attenuation ΔL _w ⁽³⁾	ISO 10140-3	25 dB
Thermal resistance R _t	-	0,92 m ² K/W
Resistance to airflow r	ISO 9053	< 10,0 kPa·s·m ⁻²
Compressibility class	EN 12431	CP2
CREEP Viscous sliding under compression X _{ct} (1,5 kPa)	EN 1606	7,50 %
Compression deformation stress	ISO 3386-1	17 kPa
Thermal conductivity λ	-	0,035 W/m·K
Specific heat c	-	1800 J/kg·K
Water vapour transmission Sd	-	> 100 m
Reaction to fire	EN 13501-1	class F
VOC emission classification	French decree no. 2011-321	A+

⁽¹⁾ΔL_w = (13 lg(m')) - (14,2 lg(s')) + 20,8 [dB] con m' = 125 kg/m².

⁽²⁾f₀ = 160 √(s'/m') con m' = 125 kg/m².

⁽³⁾Measured in the laboratory on 200 mm CLT floor. See the manual for more information on configuration.

EN ISO 12354-2 ANNEX C | ESTIMATE ΔL_w (FORMULA C.4) E ΔL (FORMULA C.1)

The following tables show how the attenuation in dB (ΔL_w e ΔL) of SILFLOORPUR20 varies as the load m' (i.e., the surface mass of the layers with which SILFLOORPUR20 is loaded) changes.

SILFLOORPUR20

s't or s'	12,5	12,5	12,5	12,5	12,5	12,5	12,5	12,5	12,5	12,5	12,5	12,5	[MN/m ³]
load m'	50	75	100	125	150	175	200	225	250	275	300		[kg/m ²]
ΔL _w	27,3	29,6	31,2	32,5	33,5	34,4	35,1	35,8	36,4	36,9	37,4		[dB]
f ₀	80,0	65,3	56,6	50,6	46,2	42,8	40,0	37,7	35,8	34,1	32,7		[Hz]

ΔL in frequency

[Hz]	100	2,9	5,5	7,4	8,9	10,1	11,1	11,9	12,7	13,4	14,0	14,6	[dB]
[Hz]	125	5,8	8,5	10,3	11,8	13,0	14,0	14,8	15,6	16,3	16,9	17,5	[dB]
[Hz]	160	9,0	11,7	13,5	15,0	16,2	17,2	18,1	18,8	19,5	20,1	20,7	[dB]
[Hz]	200	11,9	14,6	16,5	17,9	19,1	20,1	21,0	21,7	22,4	23,0	23,6	[dB]
[Hz]	250	14,8	17,5	19,4	20,8	22,0	23,0	23,9	24,6	25,3	26,0	26,5	[dB]
[Hz]	315	17,9	20,5	22,4	23,8	25,0	26,0	26,9	27,7	28,3	29,0	29,5	[dB]
[Hz]	400	21,0	23,6	25,5	26,9	28,1	29,1	30,0	30,8	31,5	32,1	32,6	[dB]
[Hz]	500	23,9	26,5	28,4	29,8	31,0	32,0	32,9	33,7	34,4	35,0	35,5	[dB]
[Hz]	630	26,9	29,5	31,4	32,9	34,0	35,0	35,9	36,7	37,4	38,0	38,6	[dB]
[Hz]	800	30,0	32,6	34,5	36,0	37,2	38,2	39,0	39,8	40,5	41,1	41,7	[dB]
[Hz]	1000	32,9	35,5	37,4	38,9	40,1	41,1	41,9	42,7	43,4	44,0	44,6	[dB]
[Hz]	1250	35,8	38,5	40,3	41,8	43,0	44,0	44,8	45,6	46,3	46,9	47,5	[dB]
[Hz]	1600	39,0	41,7	43,5	45,0	46,2	47,2	48,1	48,8	49,5	50,1	50,7	[dB]
[Hz]	2000	41,9	44,6	46,5	47,9	49,1	50,1	51,0	51,7	52,4	53,0	53,6	[dB]
[Hz]	2500	44,8	47,5	49,4	50,8	52,0	53,0	53,9	54,6	55,3	56,0	56,5	[dB]
[Hz]	3150	47,9	50,5	52,4	53,8	55,0	56,0	56,9	57,7	58,3	59,0	59,5	[dB]

EN ISO 12354-2 Annex C - formula C.4

$$\Delta L_w = \left(13 \lg(m') \right) - \left(14,2 \lg(s') \right) + 20,8 \text{ dB}$$

EN ISO 12354-2 Annex C - formula C.1

$$\Delta L = \left(30 \lg \frac{f}{f_0} \right) \text{ dB}$$

EN ISO 12354-2 Annex C - formula C.2

$$f_0 = 160 \sqrt{\frac{s'}{m'}}$$

LABORATORY MEASUREMENT | CLT FLOOR 1

MEASUREMENT OF THE EVALUATION INDEX OF THE REDUCTION OF THE IMPACT SOUND PRESSURE LEVEL
 REFERENCE STANDARD: ISO 10140-3 AND EN ISO 717-2

FLOOR SLAB

Surface = 13,71 m²

Surface mass = 216,2 kg/m²

Receiving room volume = 60,1 m³

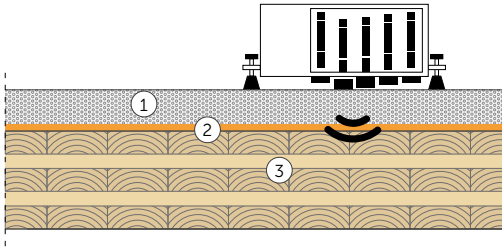

- ① Concrete screed (thickness: 50 mm); (2600 kg/m³); (130 kg/m²)
- ② SILENT FLOOR PUR - SILFLOORPUR20 (thickness: 20 mm)
- ③ CLT 5 layers (thickness: 200 mm); (420 kg/m³); (84 kg/m²)

IMPACT SOUND INSULATION

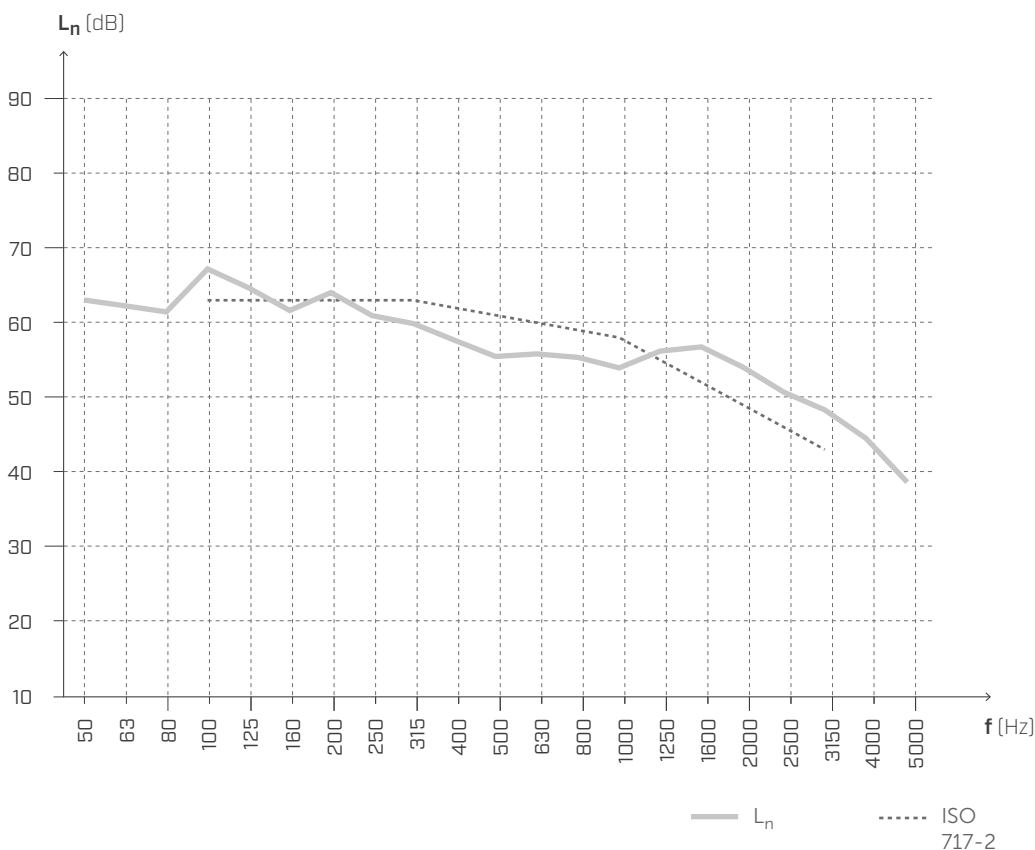

f [Hz]	L _n [dB]
50	63,0
63	62,3
80	61,4
100	67,2
125	64,7
160	61,6
200	64,0
250	60,9
315	59,9
400	57,6
500	55,5
630	55,8
800	55,3
1000	53,9
1250	56,2
1600	56,7
2000	54,1
2500	50,7
3150	48,3
4000	44,5
5000	38,6

$$L_{n,w}(C_l) = \mathbf{61 (-4) dB}$$

$$\Delta L_{n,w} = -25 \text{ dB}^{(1)}$$

$$IIC = \mathbf{49}$$

$$\Delta IIC = +25^{(2)}$$

Testing laboratory: Building Physics Lab | Libera Università di Bolzano.

Test protocol: Pr. 2022-rothoLATE-L1.

NOTES:

⁽¹⁾ Decrease due to the addition of layers no. 1 and no. 2.

⁽²⁾ Increase due to the addition of layers no. 1 and no. 2.

LABORATORY MEASUREMENT | CLT FLOOR 1

MEASUREMENT OF THE EVALUATION INDEX OF THE REDUCTION OF THE IMPACT SOUND PRESSURE LEVEL
RUBBER BALL METHOD | REFERENCE STANDARD: ISO 16283-2

FLOOR SLAB

Surface = 13,71 m²

Surface mass = 216,2 kg/m²

Receiving room volume = 60,1 m³

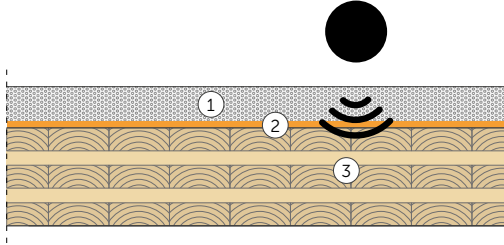

- ① Concrete screed (thickness: 50 mm); (2600 kg/m³); (130 kg/m²)
- ② **SILENT FLOOR PUR - SILFLOORPUR20** (thickness: 20 mm)
- ③ CLT 5 layers (thickness: 200 mm); (420 kg/m³); (84 kg/m²)

IMPACT SOUND INSULATION

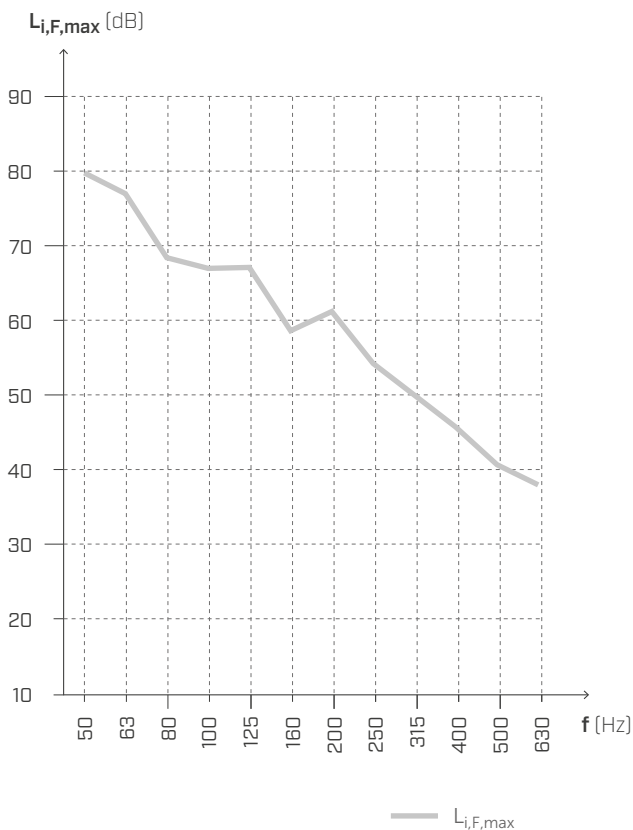

f [Hz]	L _{i,F,max} [dB]
50	79,8
63	77,0
80	68,4
100	67,0
125	67,1
160	58,6
200	61,2
250	54,2
315	50,0
400	45,7
500	40,7
630	38,0

Testing laboratory: Building Physics Lab | Libera Università di Bolzano.
Test protocol: Pr. 2022-rothoLATE-L1.

Rotho Blaas Srl does not guarantee the legal and/or design conformity of data and calculations, as Rotho Blaas provides indicative tools such as technical-commercial service within the sales activity.

Rotho Blaas Srl follows a policy of continuous development of its products, thereby reserving the right to modify their characteristics, technical specifications and other documentation without notice.

The user or the designer are responsible to verify, at each use, the conformity of the data to the regulations in force and to the project. The ultimate responsibility for choosing the appropriate product for a specific application lies with the user/designer.

The values resulting from "experimental investigations" are based on the actual test results and valid only for the test conditions specified.

Rotho Blaas Srl does not guarantee and in no case can be held responsible for damages, losses and costs or other consequences, for any reason (warranty for defects, warranty for malfunction, product or legal responsibility, etc.) deriving from the use or inability to use the products for any purpose; from non-conforming use of the product;

Rotho Blaas Srl is not liable in any way for any errors in printing and/or typing. In the event of differences between the contents of the catalogue versions in the various languages, the Italian text is binding and takes precedence with respect to the translations.

Pictures are partially completed with accessories not included. Images are for illustration purposes only. Packaged quantities may vary.

This catalogue is private property of Rotho Blaas Srl and may not be copied, reproduced or published, totally or in part, without prior written consent. All violations will be prosecuted according to law.

The general purchase conditions of Rotho Blaas Srl are available on the website www.rothoblaas.com.

Rotho Blaas Srl

Via dell'Adige N.2/1 | 39040, Cortaccia (BZ) | Italia
Tel: +39 0471 81 84 00 | Fax: +39 0471 81 84 84
info@rothoblaas.com | www.rothoblaas.com

